

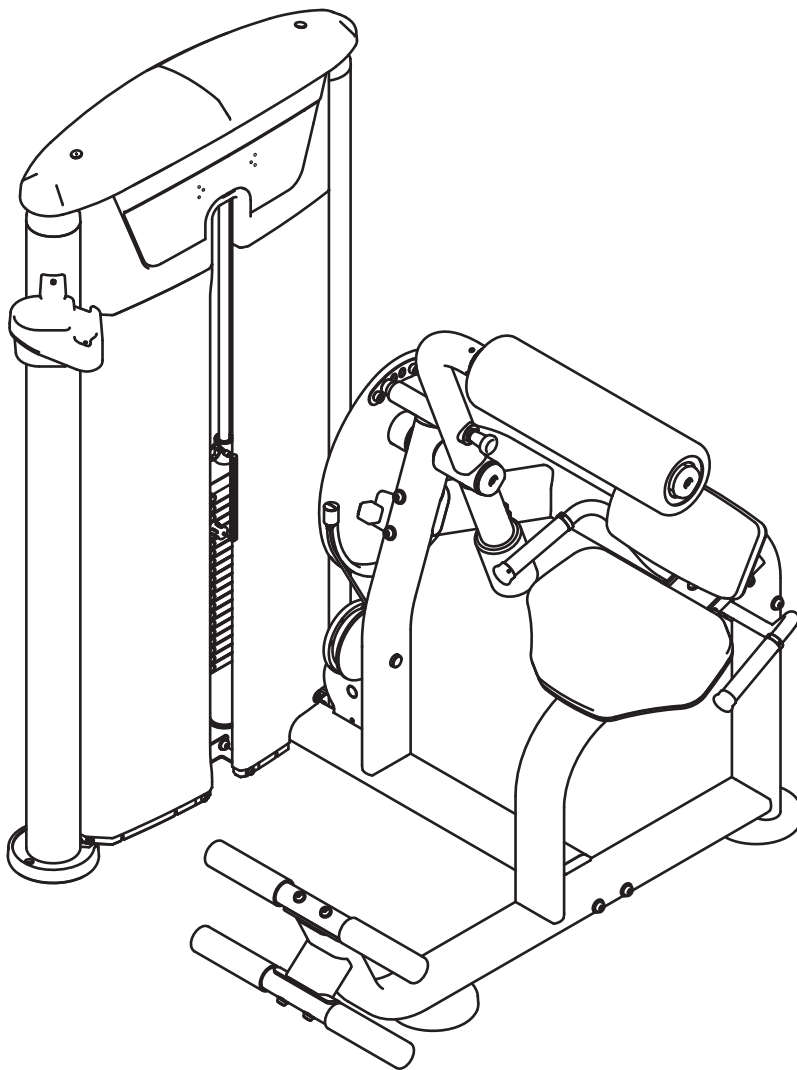

# 7023-G2

BACK EXTENSION

## Owner's Manual



### **! CAUTION**

Read all precautions  
and instructions in this manual  
before using this equipment

# Table Of Contents

## CAUTION!

Read all precautions and instructions in this manual before using this equipment.

Important Safety Instructions-----	3
Instructions-----	5
Exploded View and Parts List-----	6
Measurement Guide-----	15
Assembly Instructions-----	16
Assembly-----	17
Adjust Instructions-----	31
Exercise Instructions-----	31
Maintenance Schedule-----	32
General Maintenance Information-----	33
Weight Training Tips-----	34

Please assemble according to the actual **Weights and Shroud** you buy !

---

# Important Safety Instructions

Before beginning any fitness program, you should obtain a complete physical examination from your physician. When using exercise equipment, basic precautions should always be taken, including the following:

1. Read all instructions before using the equipment.  
These instructions are written to ensure your safety and to protect the unit.
2. Use the equipment only for its intended purpose as described in this guide.  
Do not use accessory attachments that are not recommended by the manufacturer: such attachments might cause injuries.
3. The product should only be used on a level surface and is with 0.6 meters space around the product.  
Do not use the equipment outdoors.
4. Do not allow children on or near the equipment. And children are not allowed to use this equipment.  
Teenagers should use this equipment with adult supervision.
5. Do not overexert yourself or work to exhaustion.  
Do not attempt to lift more weight than you can control safely.  
If you feel any pain or abnormal symptoms, stop your workout immediately and consult your physician.
6. This equipment is not used as medical apparatus and instruments.
7. Never operate the unit when it has been dropped or damaged.  
Never drop or insert anything into any opening in the equipment.  
Always check the unit and its cables before each use. Make sure that all fasteners and cables are secure and in good working condition.  
Frayed or worn cables can be dangerous and may cause injury. Periodically check these cables for any indication of wear.  
Keep hands, limbs, loose clothing and long hair well out of the way of moving parts.
8. Be careful when getting on or off the equipment.
9. Wear proper exercise clothing and shoes for your workout, no loose clothing.

# Important Safety Instructions

## Personal Safety During Assembly

Read each step in the assembly instructions and follow the steps in sequence. Do not skip ahead. If you skip ahead, you may learn later that you have to disassemble components and that you may have damaged the equipment.

Assemble and operate the equipment on a solid, level surface. Locate the unit a few feet from walls or furniture to provide easy access. The equipment is designed for your enjoyment. By following these precautions and using common sense, you will have many safe and pleasurable hours of healthful exercise with the equipment.

## Training Area and Free Area

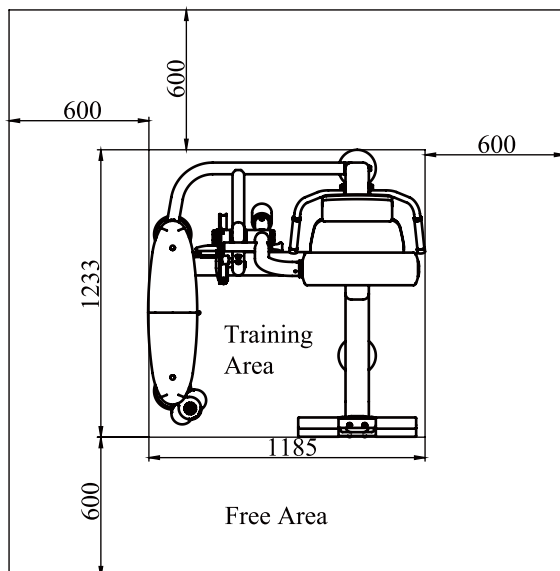

## Specifications

Class: S

Maximum Wt. Capacity: 134kg/ 295lbs

Maximum User Weight: 150kg/ 330lbs

Product Dimension: 1185\*1233\*1506mm

Product Total Surface: 1185\*1233mm

Product Total Mass: 123.7kg/ 273lbs

# Instructions

Before beginning assembly please take the time to read instructions thoroughly. Please use the various lists in this manual to make sure that all parts have been included in your shipment. When ordering, use part number and description from the lists. Use only our replacement part when servicing. Failure to do so will void your warranty and could result in personal injury.

The equipment is designed to provide the smoothest, most effective exercise motion possible. After assembly, you should check all functions to ensure correct operation. If you experience problems, first recheck the assembly instructions to locate any possible errors made during assembly. If you are unable to correct the problem, call your authorized dealer. Be sure to have your serial number and this manual when calling. When all parts have been accounted for, continue on.

## Tools Required

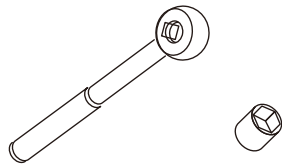

Ratchet Wrench and Socket

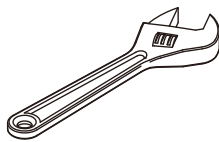

Adjustable Wrench

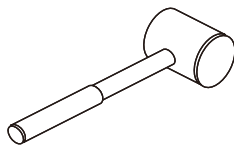

Rubber Mallet

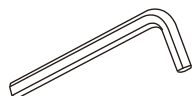

Hex Key Wrench Set

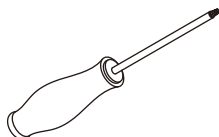

Phillips Screwdriver

# Exploded View and Parts List

## Overall

Item No.	Grade No.	Part No.	Description	QTY
1	1	IT953201ASSY	Weight Stack Frame ASSY	1
2	2	IT95320200	Main Frame	1
3	3	IT953203ASSY	Bottom Cross Brace ASSY	1
4	4	IT95320400	Rear Connection Frame	1
5	5	IT953205ASSY	Swing Frame ASSY	1
6	6	IT953206ASSY	Wheel Frame ASSY	1
7	7	IT951709ASSY	Circular Foot Frame ASSY	2
8	8	IT950509ASSY	Handle Frame ASSY	1
9	9	IT93149300	Weight Stack Space 300	2
10	10	IT950121ASSY	Top Bracket ASSY	1
11	11	IT950122ASSY	Bottom Bracket ASSY	2
12	12	IT95016000	Plastic Cover	3
13	13	IT95012300	Rear Bracket	1
14	14	IT95014200	Top Plate	1
15	15	IT95014400	Guide Rod $\Phi 19 \times 1242$	1
16	16	IT95015100	Top Cover	1
17	17	IT95015200	Training Placard Cover	1
18	18	IT95015500	Top Rear Shroud	1
19	19	IT95016600	Cup Holder	1
20	20	SD1000B3000ASSY	Adjustable Foot Plate	2
21	21	SG500110400V5	4.5" Pulley	3
22	22	IE950528ASSY	FOAM ASSY	1
23	23	IT95081800	Seat Pad	1
24	24	IT95322000	Lumbar Pad	1
25	25	IT95015300	Front Shroud	1
26	26	IT95015400	Right Front Shroud	1
27	27	IT95015600	Rear Shroud	1
28	28	IT80023000	Weight Rubber Bumper	2
29	29	IT90012000V1	Selector Pin W/Coil	1
30	30	FE97212000	Circle Ring $\Phi 62.5 \times 5$	2

# Exploded View and Parts List

## Overall

Item No.	Grade No.	Part No.	Description	QTY
31	31	HFOPT900-04A1400	Aluminium Sheath	1
32	32	IT95016500	Spout Plug $\Phi 16.5 \times 6.88$	2
33	33	V22500	Plug	1
34	34	FE97211900	Cap $\Phi 60$	3
35	35	GB818M6*16DHS2	Cross Recessed Pan Head Screw M6*16	4
36	36	GB818M6*10DHS2	Cross Recessed Pan Head Screw M6*10	4
37	37	GB818M6*20DHS2	Cross Recessed Pan Head Screw M6*20	18
38	38	GB70M8*20N19	Socket Head Cap Screw M8*20	2
39	39	GB70BTM10*25DN18	Socket Head Cap Screw M10*25	5
40	40	GB70BTM10*50DN18	Socket Head Cap Screw M10*50	3
41	41	GB70BTM10*65DN18	Socket Head Cap Screw M10*65	4
42	42	GB70BTM10*75DN18	Socket Head Cap Screw M10*75	2
43	43	GB70BTM10*80DN18	Socket Head Cap Screw M10*80	4
44	44	GB70BTM10*130DN18	Socket Head Cap Screw M10*130	2
45	45	GB70BTM12*30DN18	Socket Head Cap Screw M12*30	2
46	46	GB70BTM12*135DN18	Socket Head Cap Screw M12*135	6
47	47	IT95016100	Guide Rod Fixing Sleeve $\Phi 25 \times \Phi 19 \times 45$	2
48	48	GB958DN2	Flat Washer $\Phi 9 \times \Phi 16 \times 1.6$	2
49	49	GB9510DN2	Flat Washer $\Phi 11 \times \Phi 20 \times 2$	28
50	50	GB9512DN2	Flat Washer $\Phi 13 \times \Phi 24 \times 2.5$	8
51	51	NM10DN2	Nylon Lock Nut M10	9
52	52	HFOPT900-04A0602	Spring	2
53	54	IT95325400	Cable ASSY	1
54	55	GB70BTM10*30DN18	Socket Head Cap Screw M10*30	2
55	56	IE950912800	Plastic Ring	1
56	70	NBS6DHS	Hex Key S=6	1
57	71	NBS8DHS	Hex Key S=8	1
58	72	LW200BS	Wrench $\Phi 6 \times 117$	1
59	73	YHY	Lube	1
200	200	IT9501C3100	Half Rear Shroud	1

# Exploded View and Parts List

Overall

Full Shroud

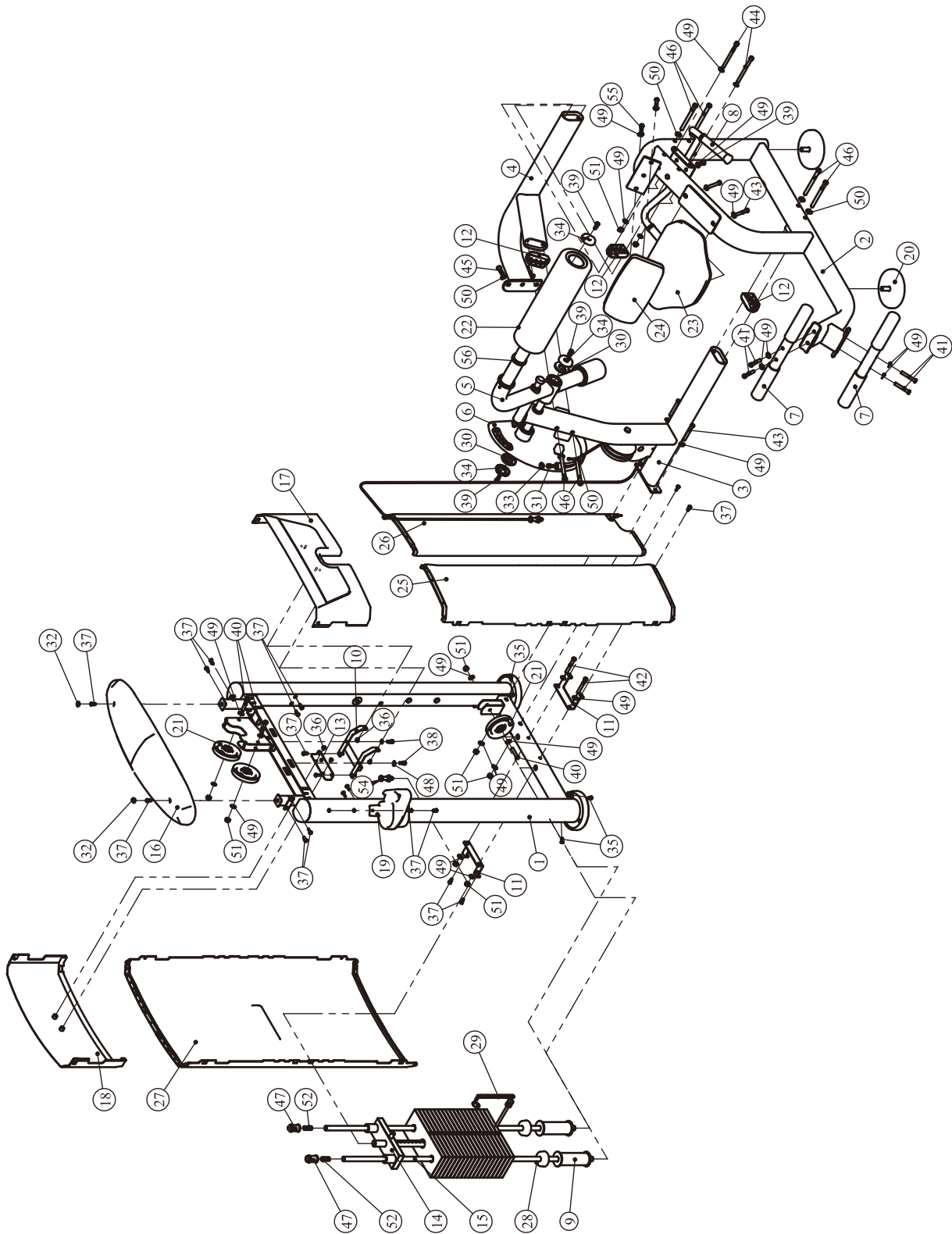

# Exploded View and Parts List

Overall

## Half Rear Shroud

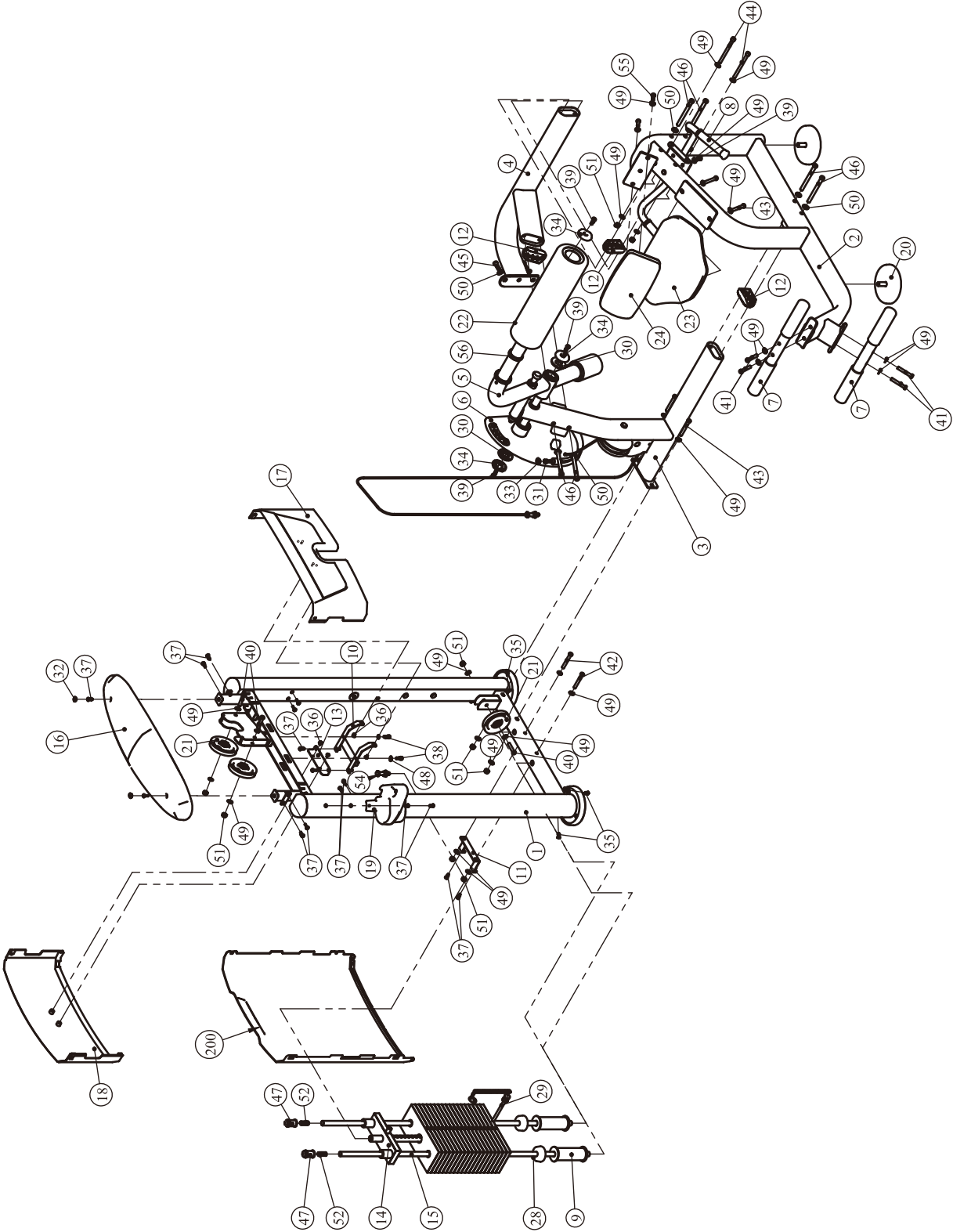

# Exploded View and Parts List

## Weight Stack Frame ASSY

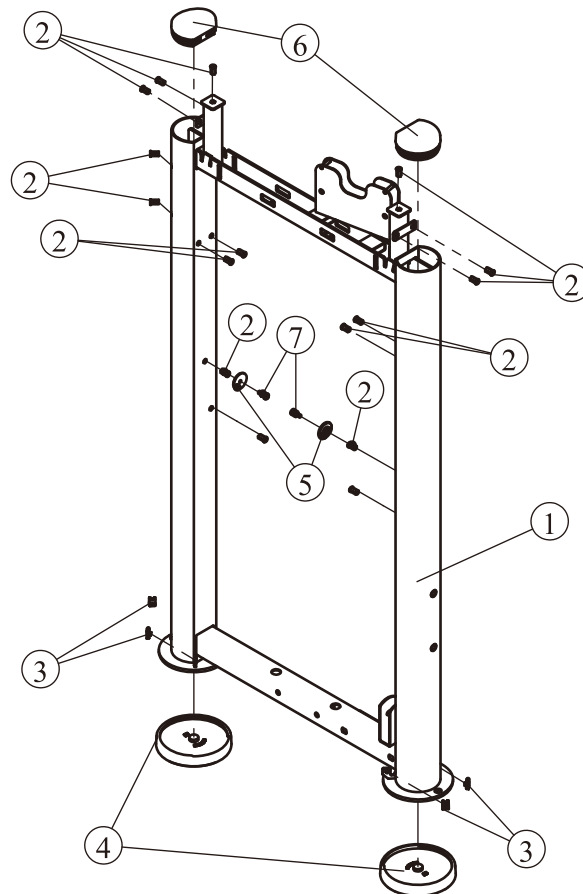

Item No.	Grade No.	Part No.	Description	QTY
1	1.1	IT95320100	Weight Stack Frame	1
2	1.2	GB17880.5M6*16.5DS17	Rivet Nut M6	16
3	1.3	AC32705800	U-nut M6	4
4	1.4	IT95015700	Foot Plate	2
5	1.5	IT95015900	Plastic Block	2
6	1.6	IT95015800	Plug $\Phi 95 \times 81.1$	2
7	1.7	GB818M6*20DHS2	Cross Recessed Pan Head Screw M6*20	2

# Exploded View and Parts List

## Bottom Cross Brace ASSY

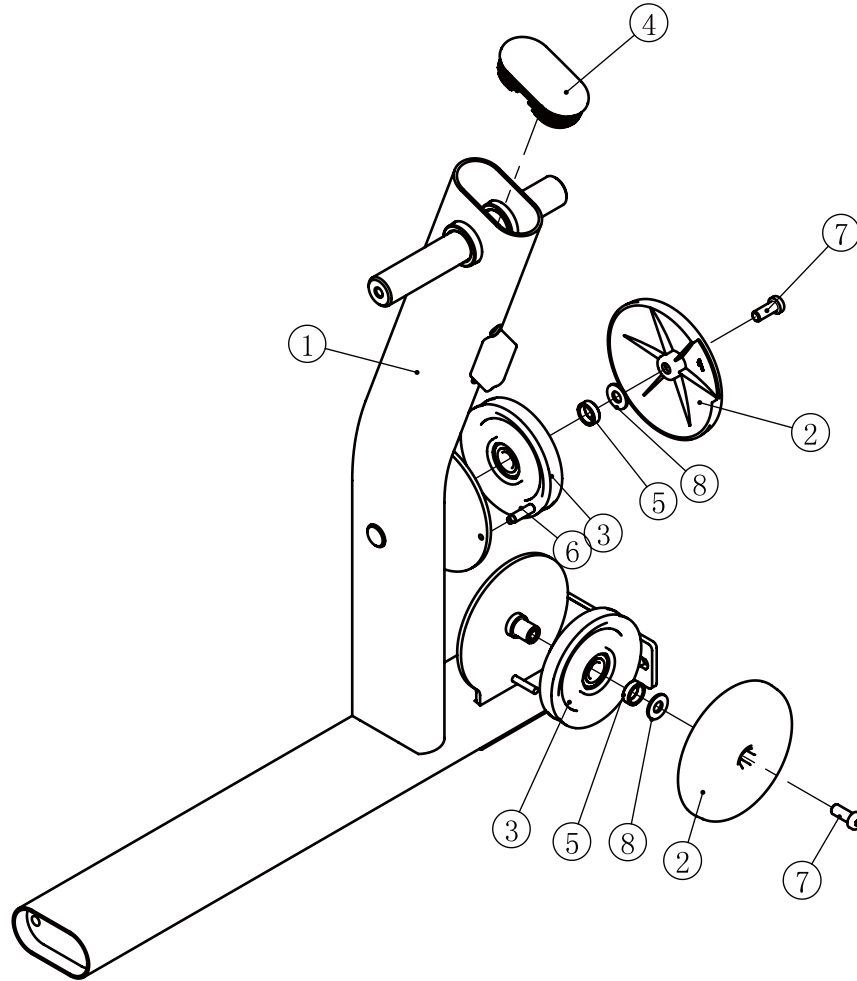

Item No.	Grade No.	Part No.	Description	QTY
1	3.1	IT95320300	Bottom Cross Brace	1
2	3.2	IT95016400	Pulley Cover	2
3	3.3	IT95057800	Thin 4.5" Pulley	2
4	3.4	IT90013800P11C	Plug RT50*100	1
5	3.5	FE97122100	Pulley Spacer 1	2
6	3.6	FE97122300	Threaded Cloumn	1
7	3.7	GB70BTM10*25DN18	Socket Head Cap Screw M10*25	2
8	3.8	DQ10N19B	Flat Washer $\Phi 11 * \Phi 25 * 2$	2

# Exploded View and Parts List

## Swing Frame ASSY

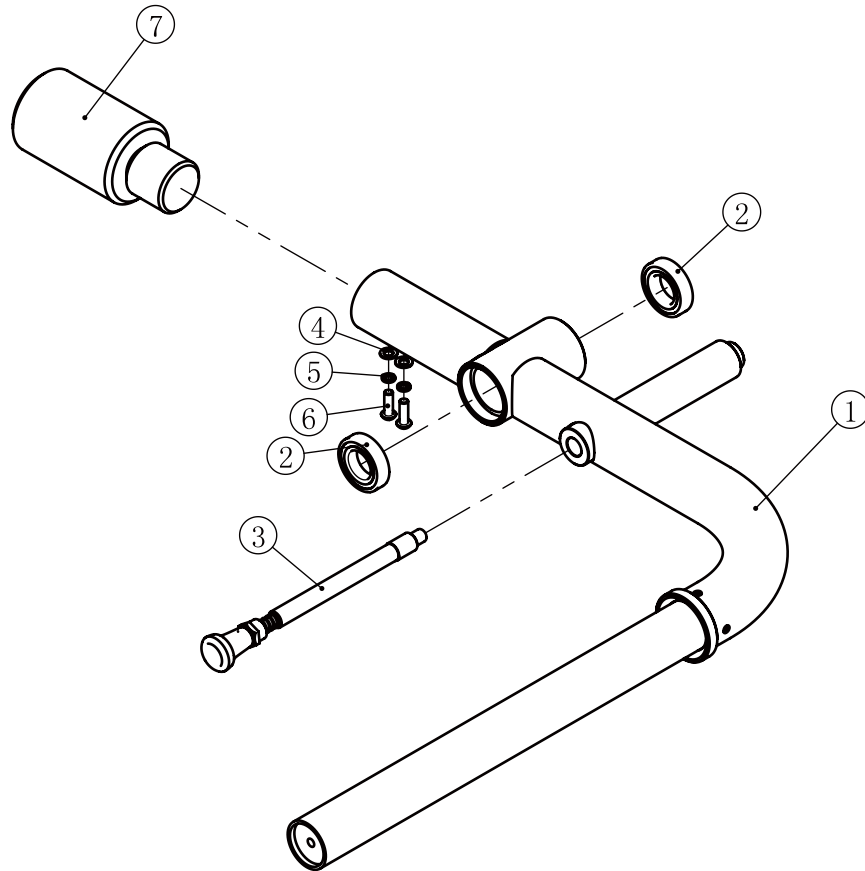

Item No.	Grade No.	Part No.	Description	QTY
1	5.1	IT95320500	Swing Frame	1
2	5.2	GB2766006-2RSC3NBK	Bearing	2
3	5.3	IT950521ASSY	Long Pin	1
4	5.4	GB958DN2	Flat Washer $\Phi 9 \times \Phi 16 \times 1.6$	2
5	5.5	GB938N19	Spring Washer $\Phi 8$	2
6	5.6	PNLM8*25DN20	Button Head Cap Screw M8*25	2
7	5.7	IT95121200	Counter Poise Block	1

# Exploded View and Parts List

## Wheel Frame ASSY

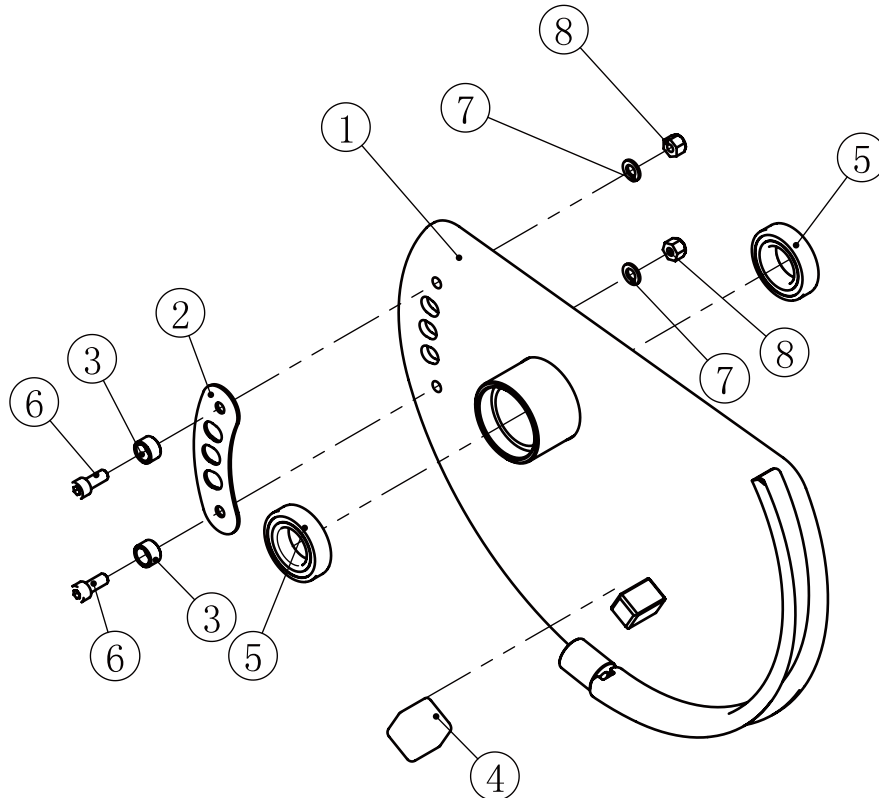

Item No.	Grade No.	Part No.	Description	QTY
1	6.1	IT95320600	Wheel Frame	1
2	6.2	IT95321800	Lining Board	1
3	6.3	IN-S10111200	Rubber Sleeve $\Phi 17 \times 10.5$	2
4	6.4	FE97213100	Square Rubber Sleeve	1
5	6.5	GB2766006-2RSC3NBK	Bearing	2
6	6.6	GB70M8*20DS20	Socket Head Cap Screw M8*20	2
7	6.7	GB958DN2	Flat Washer $\Phi 9 \times \Phi 16 \times 1.6$	2
8	6.8	NM8DN2	Nylon Lock Nut M8	2

# Exploded View and Parts List

## Circular Foot Frame ASSY

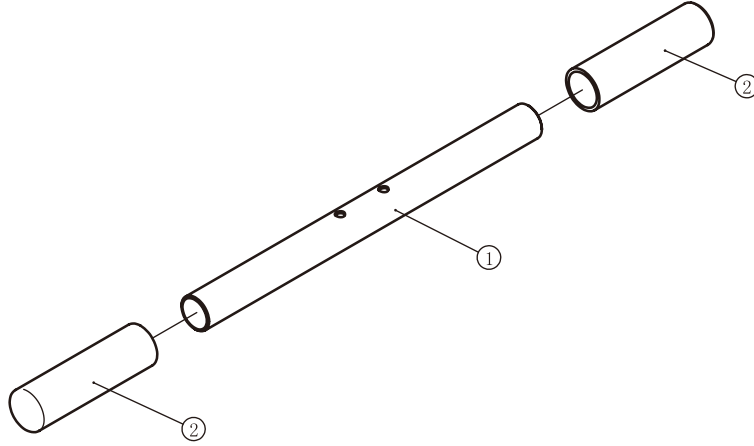

Item No.	Grade No.	Part No.	Description	QTY
1	7.1	IT95170900	Foot Set Tube	1
2	7.2	FE970112000	Foot Set	2

## Handle Frame ASSY

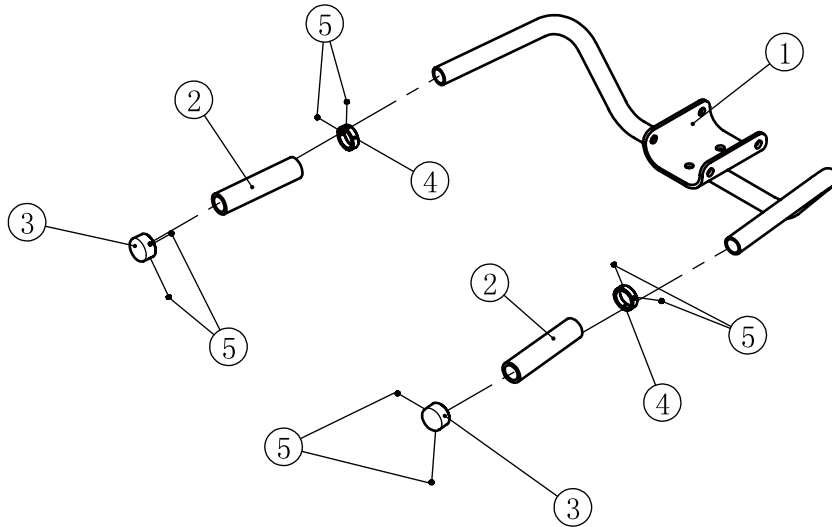

Item No.	Grade No.	Part No.	Description	QTY
1	8.1	IT95050900	Handle Frame	1
2	8.2	FE97031800	Grip	2
3	8.3	IT95022100	Aluminum Grip Cap	2
4	8.4	V39500	Aluminum Grip Ring	2
5	8.5	YZGB7710-32*3.2N19	Socket Set Screw 10-32UNF*3.2	8

# Measurement Guide

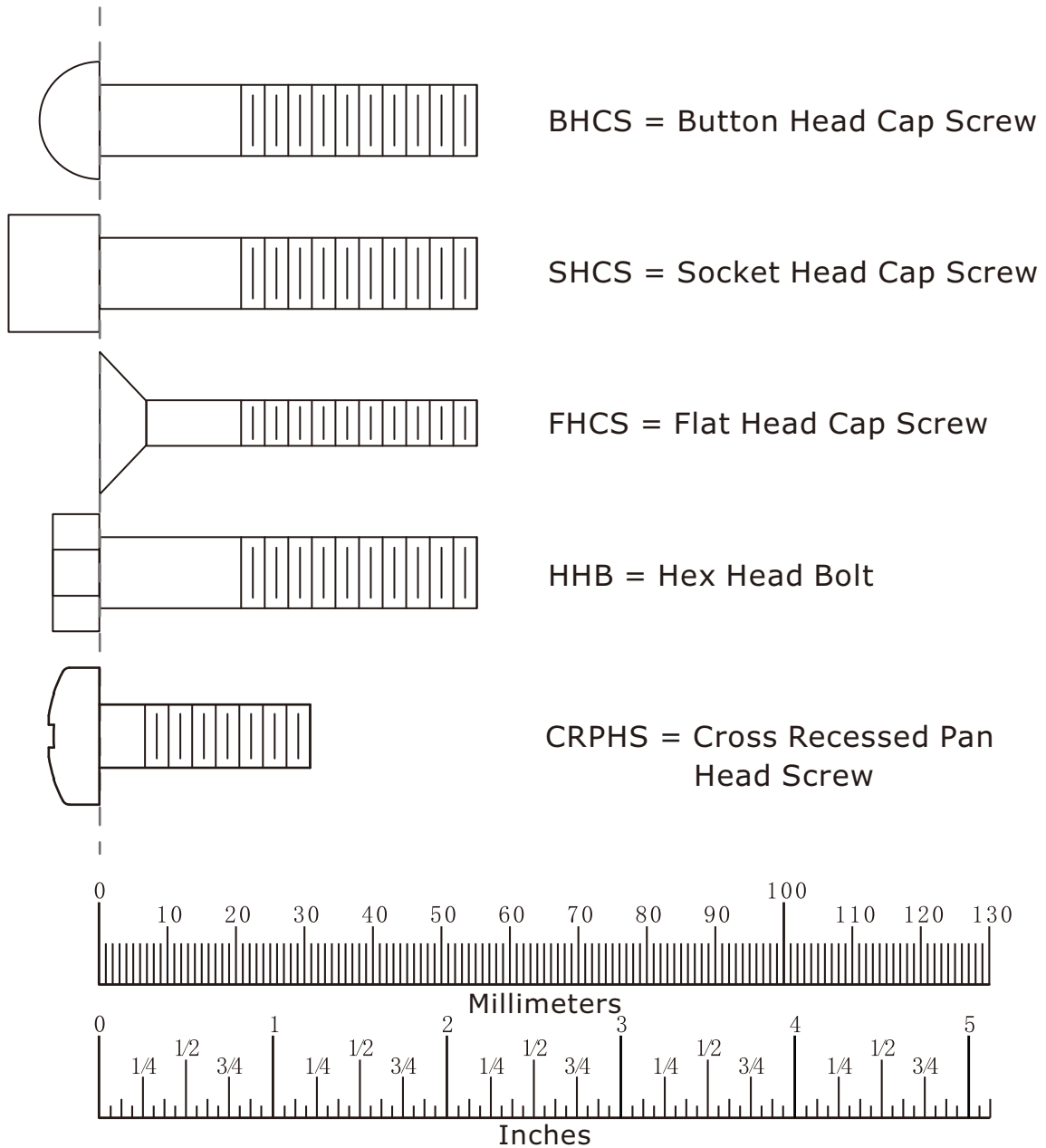

Diameter of bolt (mm/inch)	M6(1/4")	M8(5/16")	M10(3/8")	M12(1/2")	M16(5/8")
Tightening torque (N.m)	9~12	22~30	45~59	78~104	193~257
Operational methods for adult men	The strength of the wrist	The strength of the wrist and forearm	The strength of the entire arm	The strength of the arm and upper body	with all strength

# Assembly Instructions

Assembly of the equipment takes professional installers about 2 hours. If this is the first time you have assembled this type of equipment, plan to spend more time. It is strongly recommended to assemble the equipment by professional installers. You may find it quicker, safer, easier to assemble this equipment with the help of a friend, as some of components may be large, heavy or awkward to handle alone. It is important that you assemble your product in a clean, clear, uncluttered area. This will enable you to move around the product while you are fitting components and reduce the possibility of injury during assembly.

## **NOTE**

As with any assembled part, proper alignment and adjustment is critical. While tightening the fasteners, be sure to leave room for adjustments. Do not fully tighten the fasteners until instructed to do so. Be careful to assemble the components in the sequence presented in this guide.

# Assembly

## STEP 1

1. Attach two Adjustable Foot Plates (#20) to the Main Frame (#2).
2. Attach the Rear Bracket (#13) to the Top Rear Shroud (#18) using:  
two M6\*10 CRPHS (#36)

**Note: Wrench Tighten Bolts.**

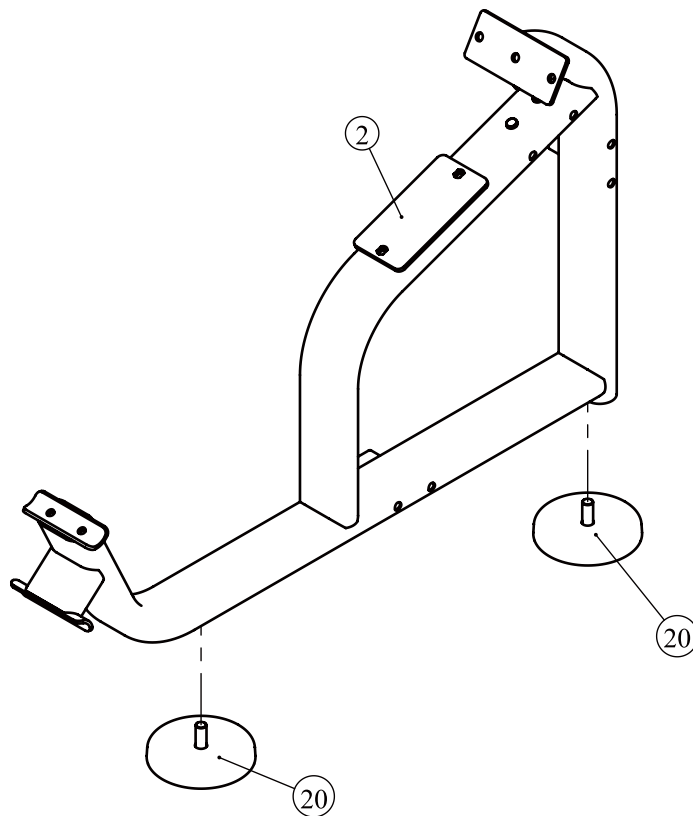
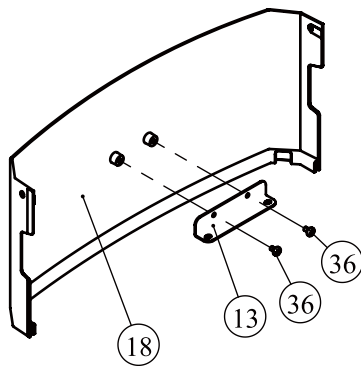

# Assembly

## STEP 2

1. Attach the Bottom Cross Brace ASSY (#3) to the Weight Stack Frame ASSY (#1) using:  
two M10\*80 SHCS (#43)                      two M10 Nylon Lock Nut (#51)  
four  $\Phi 11*\Phi 20*2$  Flat Washer (#49)
2. Attach the Rear Connection Frame (#4) to the Weight Stack Frame ASSY (#1) and the Bottom Cross Brace ASSY (#3) using:  
two M12\*30 SHCS (#45)                      two M12\*135 SHCS (#46)  
four  $\Phi 13*\Phi 24*2.5$  Flat Washer (#50)    one Plastic Cover(#12)
3. Attach the Main Frame (#2) to the Rear Connection Frame (#4) and the Bottom Cross Brace ASSY (#3) using:  
four M12\*135 SHCS (#46)                      four  $\Phi 13*\Phi 24*2.5$  Flat Washer (#50)  
two Plastic Cover (#12)

**Note: 1. Wrench Tighten Bolts and Nylon Lock Nuts.**

**2. Adjust the Adjustable Foot Plates to make the machines stable.**

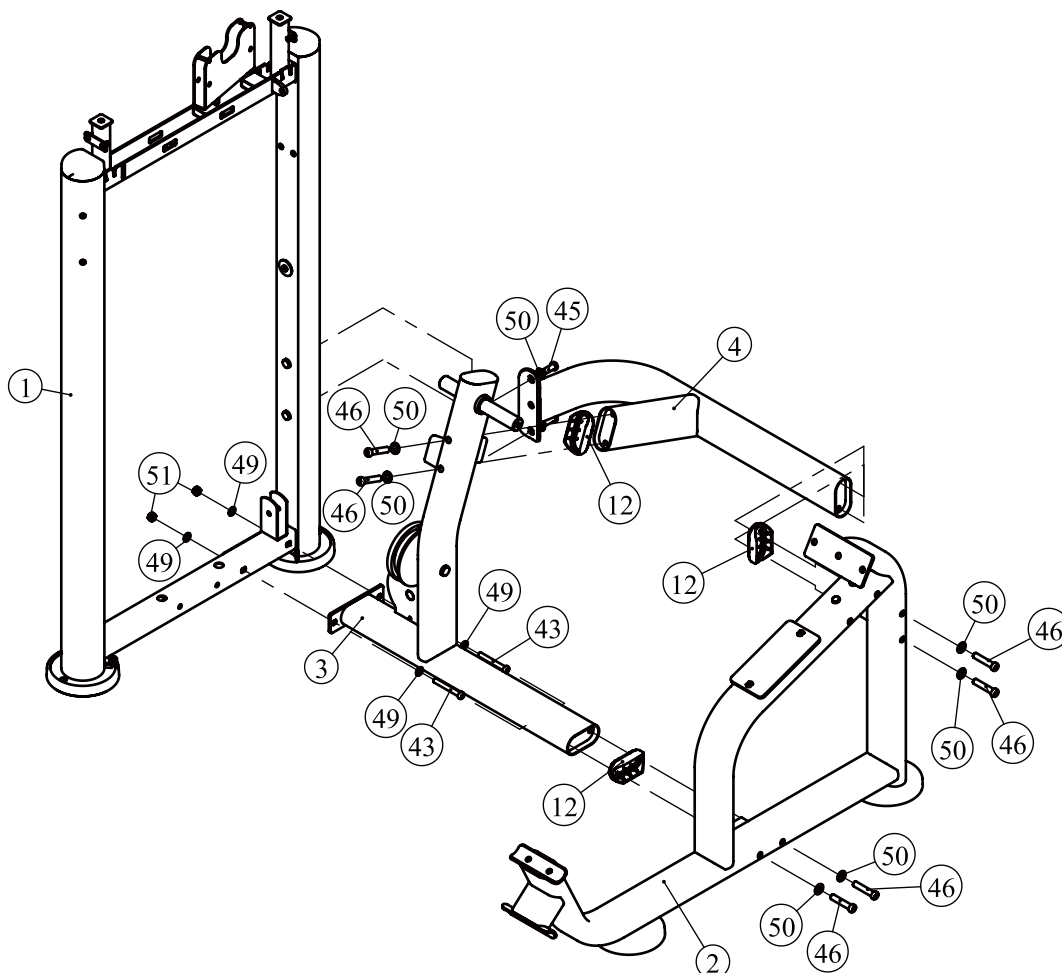

# Assembly

## STEP 3

1. Attach the 4.5" Pulley (#21) to the Weight Stack Frame ASSY (#1) using:
  - one M10\*50 SHCS (#47)
  - two  $\Phi 11*\Phi 20*2$  Flat Washer (#49)
  - one M10 Nylon Lock Nut (#51)
2. Attach two/one Bottom Bracket ASSY (#11) to the Weight Stack Frame ASSY (#1) using:
  - two M10\*75 SHCS (#42)
  - four  $\Phi 11*\Phi 20*2$  Flat Washer (#49)
  - two M10 Nylon Lock Nut (#51)
3. Attach the Top Bracket ASSY (#10) to the Weight Stack Frame ASSY (#1) using:
  - two  $\Phi 9*\Phi 16*1.6$  Flat Washer (#48)
  - two M8\*20 SHCS (#38)
4. Attach the Wheel Frame ASSY (#6) to the Bottom Cross Brace ASSY (#3) using:
  - one M10\*25 SHCS (#39)
  - one Cap  $\Phi 60$  (#34)
  - one Circle Ring  $\Phi 62.5*5$  (#30)
5. Attach the Swing Frame ASSY (#5) to the Bottom Cross Brace ASSY (#3) using:
  - one M10\*25 SHCS (#39)
  - one Cap  $\Phi 60$  (#34)
  - one Circle Ring  $\Phi 62.5*5$  (#30)
6. Attach the Handle Frame ASSY (#8) to the Main Frame (#2) using:
  - two M10\*25 SHCS (#39)
  - two M10\*130 SHCS (#44)
  - four  $\Phi 11*\Phi 20*2$  Flat Washer (#49)
  - two M10 Nylon Lock Nut (#51)
7. Attach two Circular Foot Frame ASSY (#7) to the Main Frame (#2) using:
  - four M10\*65 SHCS (#41)
  - four  $\Phi 11*\Phi 20*2$  Flat Washer (#49)

**Note: Wrench Tighten Bolts and Nylon Lock Nuts.**

# Assembly

## STEP 3

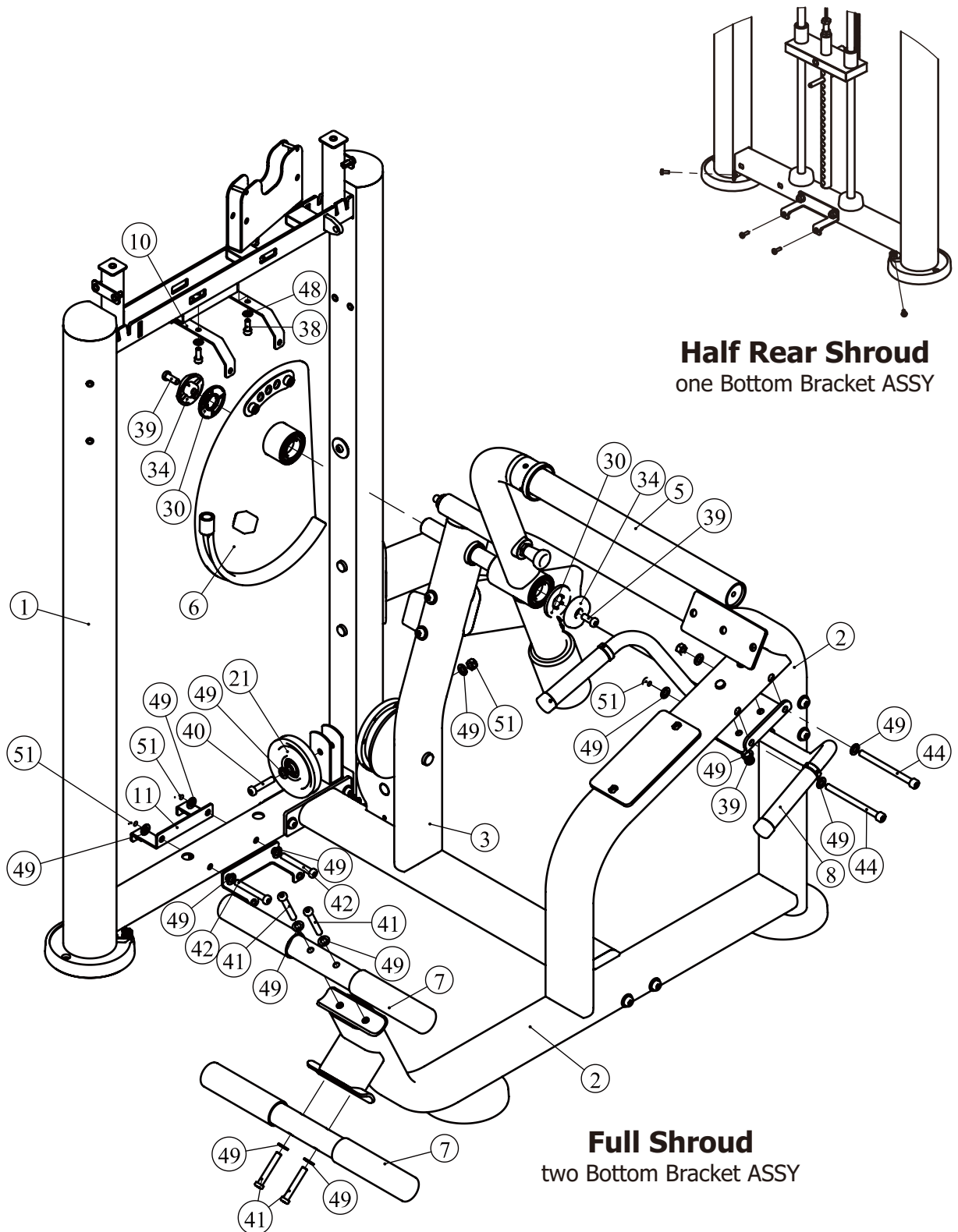

# Assembly

## STEP 4

Here is the assembly instruction for **160LBS Weights !**

### 1. Attach:

- two Guide Rod  $\Phi 19 \times 1242$  (#15)
- two Weight Rubber Bumper (#28)
- fifteen Weight Plate 10LBS (#75)
- two weight stack space(#76)
- two Weight Stack Space 300(#9)
- one Top Plate (#14)

to the Weight Stack Frame ASSY (#1) using:

- two Guide Rod Fixing Sleeve  $\Phi 25 \times \Phi 19 \times 45$  (#47)
- two Spring (#52)

### 2. Attach the Selector Pin W/Coil (#29) to the Top Plate (#14).

Grade No.	Part No.	Description	QTY
75	FE97193100	10LBS Weight Plate	15
76	FEWS01ASSY	Weight Stack Space	2

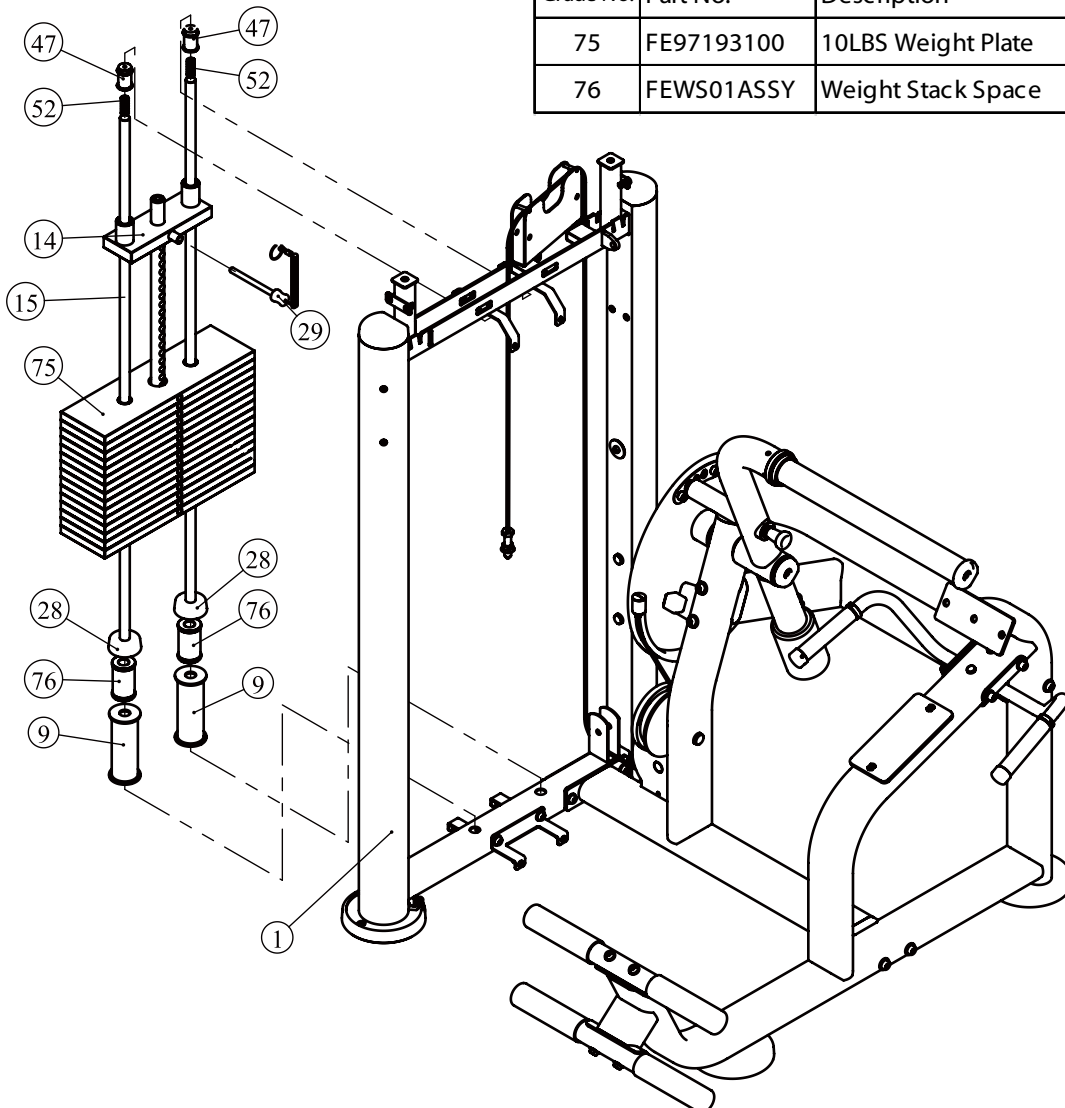

# Assembly

## STEP 4

Here is the assembly instruction for **200LBS Weights !**

### 1. Attach:

- two Guide Rod  $\Phi 19 \times 1242$  (#15)
- two Weight Rubber Bumper (#28)
- nineteen Weight Plate 10LBS (#75)
- two Weight Stack Space 300(#9)
- one Top Plate (#14)

to the Weight Stack Frame ASSY (#1) using:

- two Guide Rod Fixing Sleeve  $\Phi 25 \times \Phi 19 \times 45$  (#47)
- two Spring (#52)

### 2. Attach the Selector Pin W/Coil (#29) to the Top Plate (#14).

Grade No.	Part No.	Description	QTY
75	FE97193100	10LBS Weight Plate	19

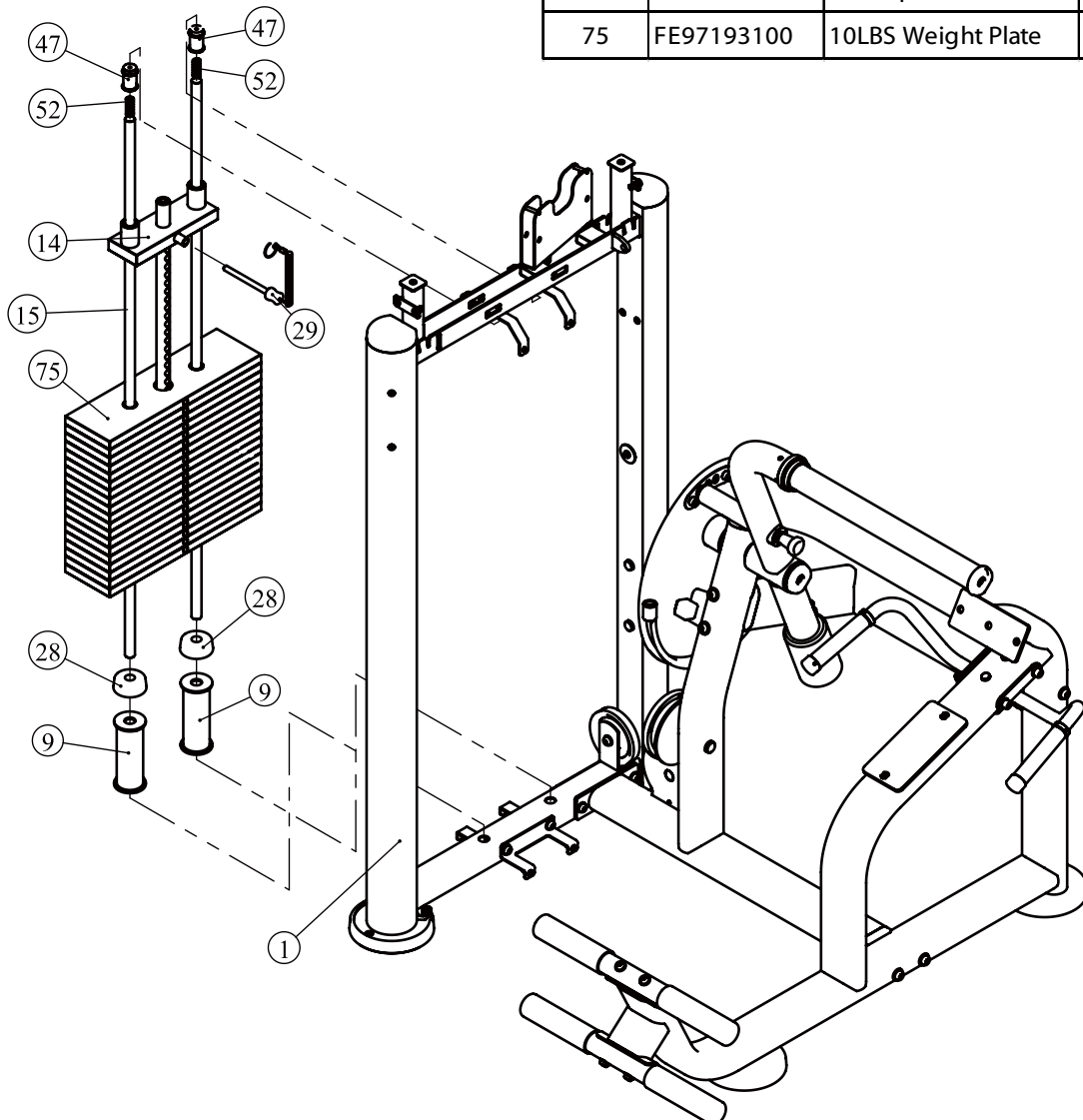

# Assembly

## STEP 4

Here is the assembly instruction for **235LBS Weights !**

### 1. Attach:

- two Guide Rod  $\Phi 19 \times 1242$  (#15)
- two Weight Rubber Bumper (#28)
- fifteen Weight Plate 15LBS (#53)
- two weight stack space(#76)
- two Weight Stack Space 300(#9)
- one Top Plate (#14)

to the Weight Stack Frame ASSY (#1) using:

- two Guide Rod Fixing Sleeve  $\Phi 25 \times \Phi 19 \times 45$  (#47)
- two Spring (#52)

### 2. Attach the Selector Pin W/Coil (#29) to the Top Plate (#14).

Grade No.	Part No.	Description	QTY
53	FE97193200	15LBS Weight Plate	15
76	FEWS01ASSY	Weight Stack Space	2

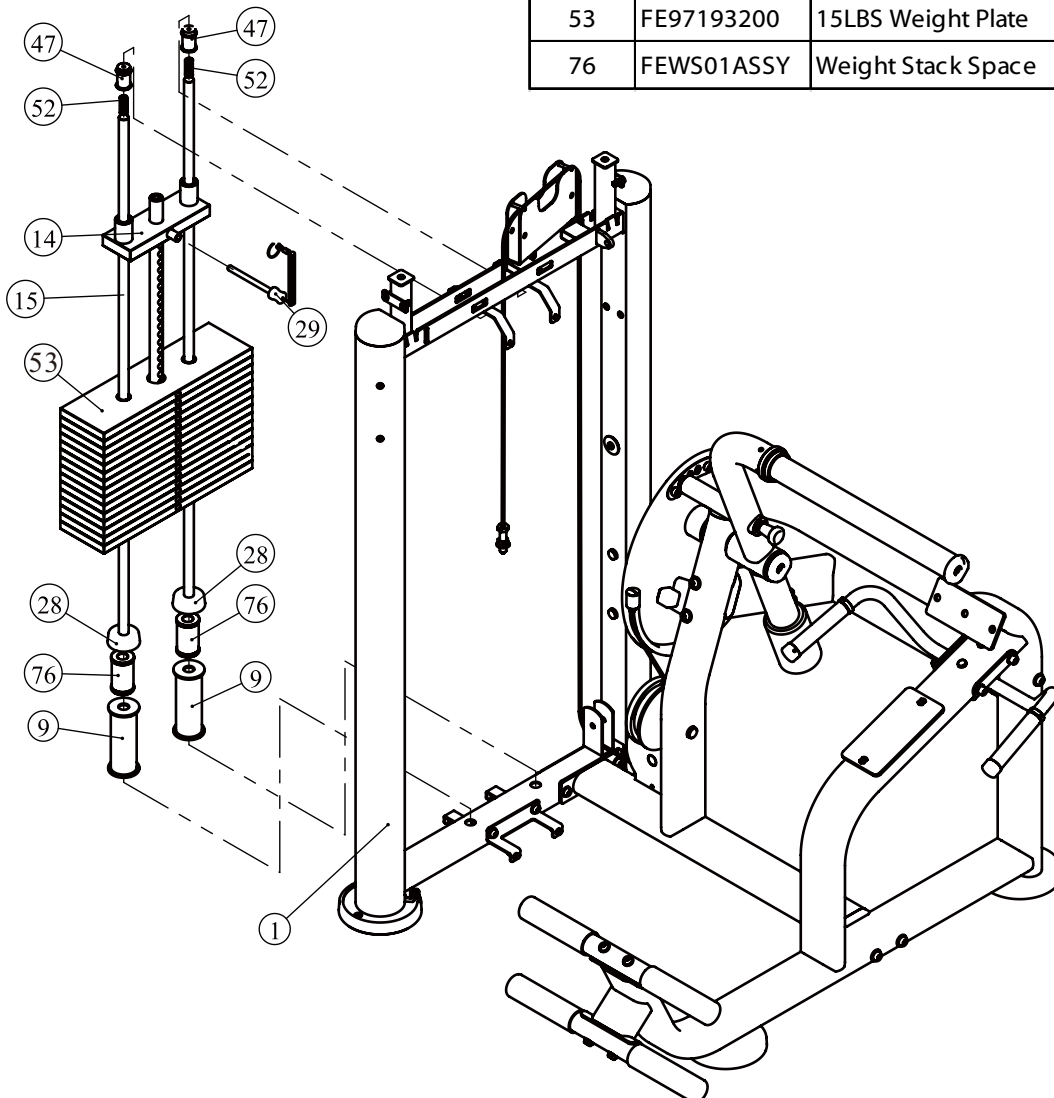

# Assembly

## STEP 4

Here is the assembly instruction for **295LBS Weights !**

### 1. Attach:

- two Guide Rod  $\Phi 19 \times 1242$  (#15)
- two Weight Rubber Bumper (#28)
- nineteen Weight Plate 15LBS (#53)
- two Weight Stack Space 300(#9)
- one Top Plate (#14)

to the Weight Stack Frame ASSY (#1) using:

- two Guide Rod Fixing Sleeve  $\Phi 25 \times \Phi 19 \times 45$  (#47)
- two Spring (#52)

### 2. Attach the Selector Pin W/Coil (#29) to the Top Plate (#14).

Grade No.	Part No.	Description	QTY
53	FE97193200	15LBS Weight Plate	19

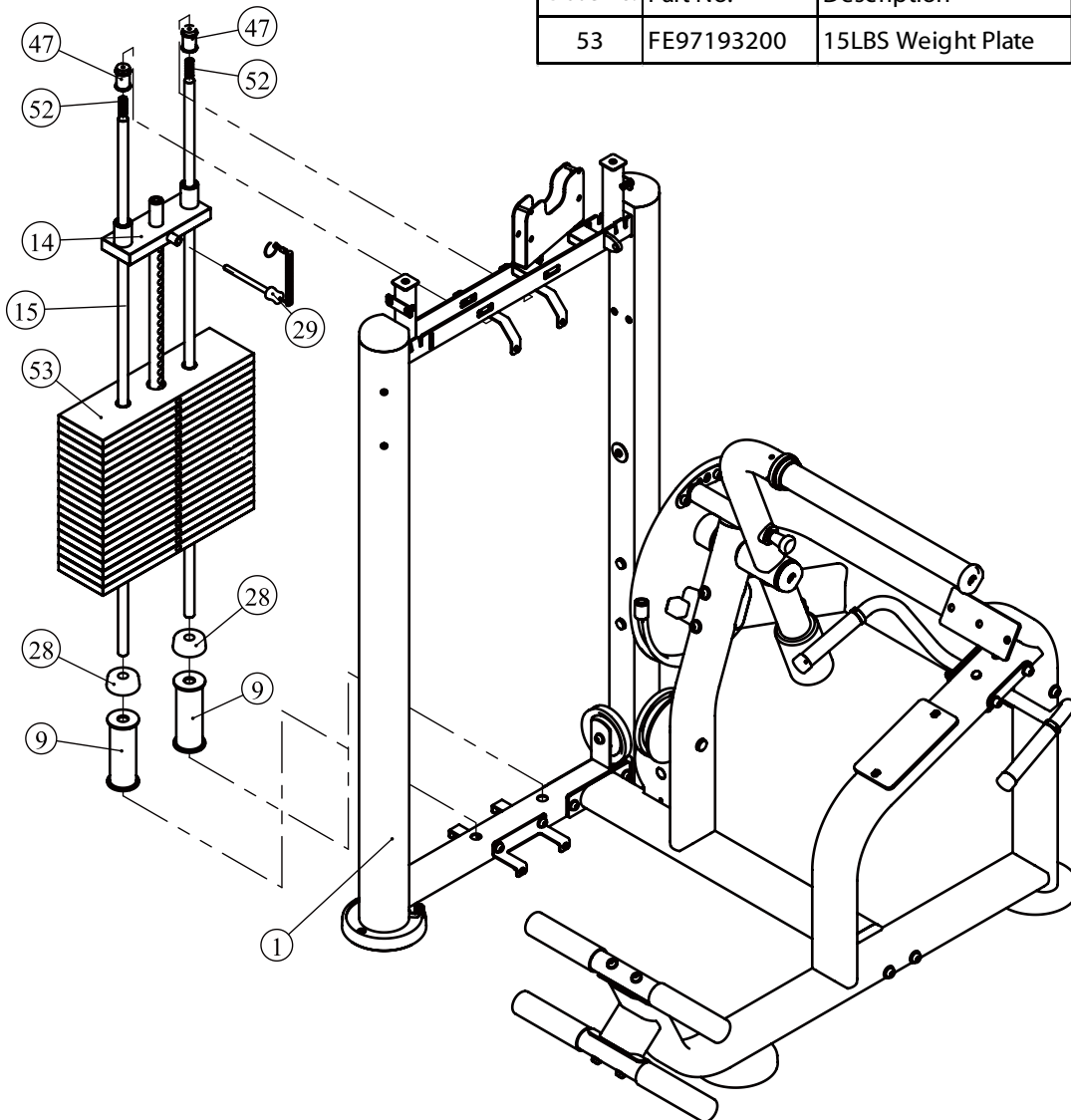

# Assembly

## All weight plate sticker paste schematic diagram

LBS 20	9
LBS 30	14
LBS 40	18
LBS 50	23
LBS 60	27
LBS 70	32
LBS 80	36
LBS 90	41
LBS 100	45
LBS 110	50
LBS 120	54
LBS 130	59
LBS 140	64
LBS 150	68
LBS 160	73
LBS 170	77
LBS 180	82
LBS 190	86
LBS 200	91
LBS 210	95
LBS 220	100
LBS 230	104

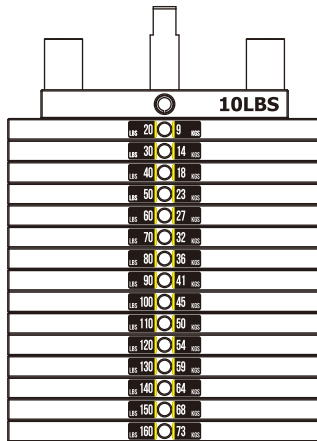

20-160LBS

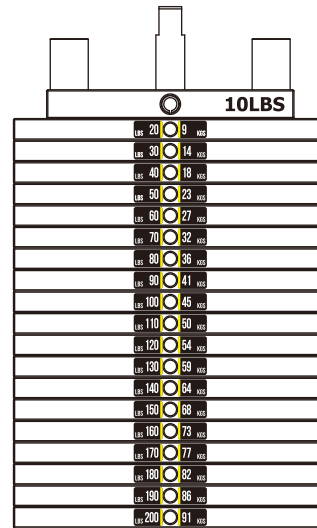

20-200LBS

LBS 25	11
LBS 40	18
LBS 55	25
LBS 70	32
LBS 85	38
LBS 100	45
LBS 115	52
LBS 130	59
LBS 145	66
LBS 160	72
LBS 175	79
LBS 190	86
LBS 205	93
LBS 220	100
LBS 235	107
LBS 250	113
LBS 265	120
LBS 280	127
LBS 295	134
LBS 310	141
LBS 325	147

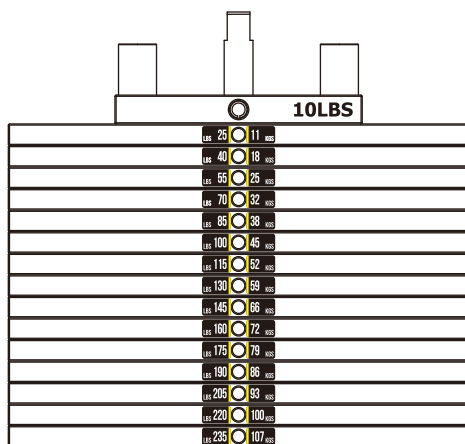

25-235LBS

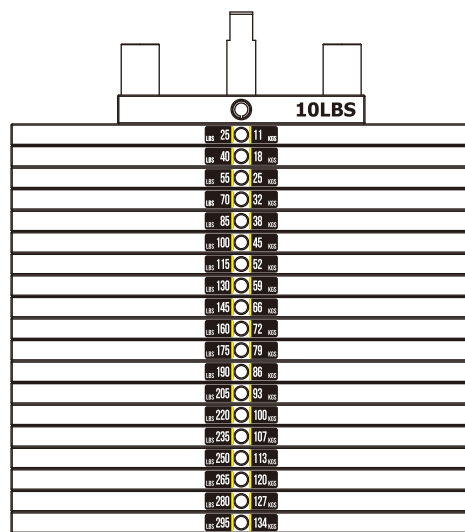

25-295LBS

# Assembly

## STEP 5

1. Attach two 4.5" Pulleys (#21) to the Weight Stack Frame ASSY (#1) using:
  - two M10\*50 SHCS (#40)
  - four  $\Phi 11*\Phi 20*2$  Flat Washer (#49)
  - two M10 Nylon Lock Nut (#51)
2. Attach the Cable ASSY (#54) to the Top Plate (#14) and the Wheel Frame ASSY (#6) using:
  - one Aluminium Sheath (#31)
  - one Plug (#33)

**Note: Wrench tighten bolts and Nylon Lock Nuts**

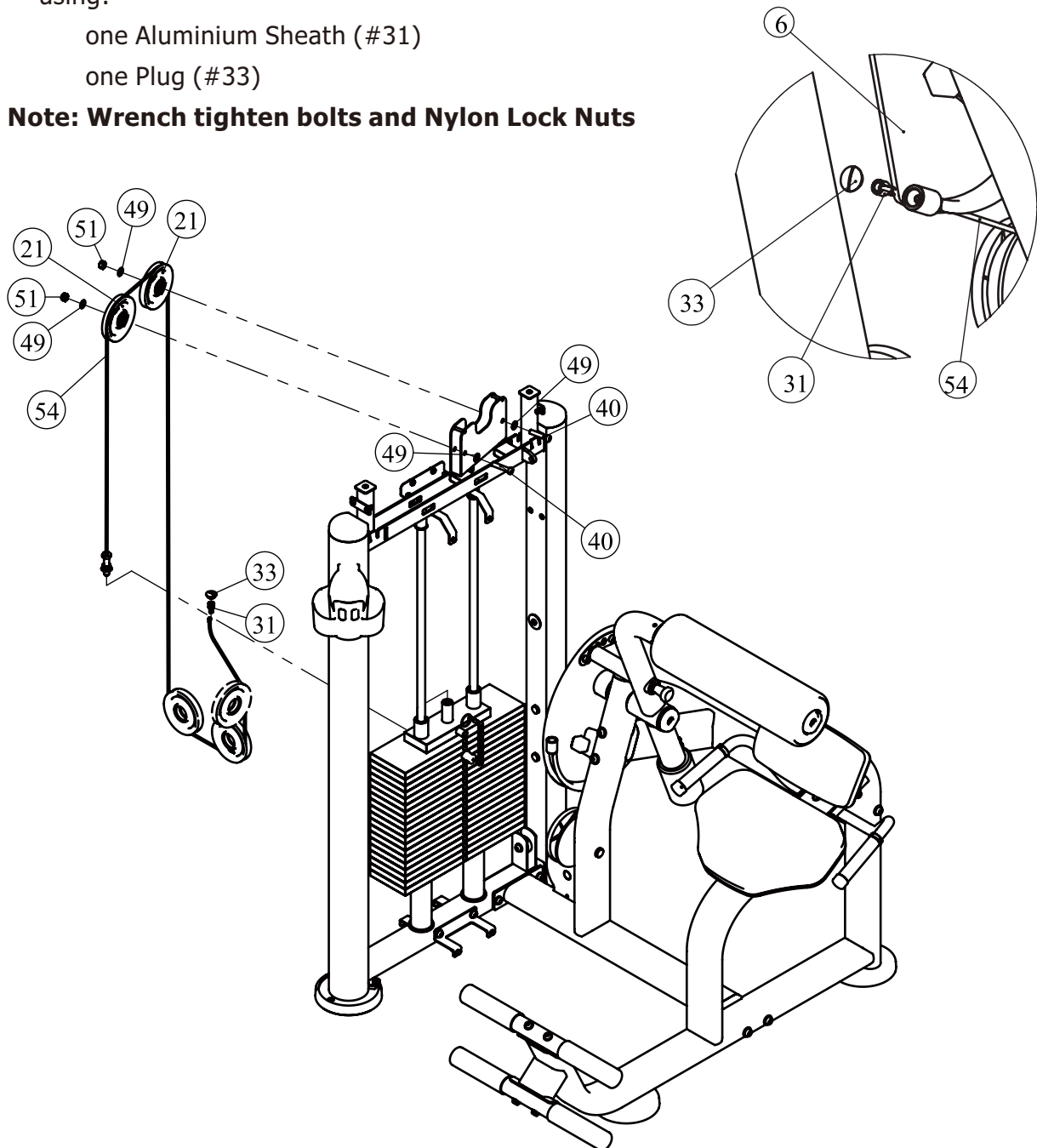

# Assembly

## Full Shroud

### STEP 6

**Tips:** Pre-assemble the 8 bolt into the Weight Stack Frame ASSY and Bottom Bracket ASSY, not wrench tighten Bolts, Assemble the shroud with the bolt on. Then wrench tighten Bolts.

1. Attach the Front Shroud (#25) and the Right Front Shroud (#26) to the Weight Stack Frame ASSY (#1) and the Bottom Bracket ASSY (#11) using:  
four M6\*20 CRPHS (#37)                      two M6\*16 CRPHS (#35)
2. Attach the Rear Shroud (#27) to the Weight Stack Frame ASSY (#1) and the Bottom Bracket ASSY (#11) using:  
four M6\*20 CRPHS (#37)                      two M6\*16 CRPHS (#35)
3. Attach the Training Placard Cover (#17) to the Weight Stack Frame ASSY (#1) and the Top Bracket ASSY (#10) using:  
two M6\*20 CRPHS (#37)                      two M6\*10 CRPHS (#36)
4. Attach the Top Rear Shroud (#18) to the Weight Stack Frame ASSY (#1) and the Top Bracket ASSY (#10) using:  
four M6\*20 CRPHS (#37)
5. Attach the Top Cover (#16) to the Weight Stack Frame ASSY (#1) using:  
two M6\*20 CRPHS (#37)                      two Spout Plug  $\Phi$ 16.5\*6.88 (#32)

## Half Rear Shroud

### STEP 6

**Tips:** Pre-assemble the 4 bolt into the Weight Stack Frame ASSY and Bottom Bracket ASSY, not wrench tighten Bolts, Assemble the shroud with the bolt on. Then wrench tighten Bolts.

1. Attach the Half Rear Shroud (#200) to the Weight Stack Frame ASSY (#1) and the Bottom Bracket ASSY (#11) using:  
four M6\*20 CRPHS (#37)                      two M6\*16 CRPHS (#35)
2. Attach the Training Placard Cover (#17) to the Weight Stack Frame ASSY (#1) and the Top Bracket ASSY (#10) using:  
two M6\*20 CRPHS (#37)                      two M6\*10 CRPHS (#36)
3. Attach the Top Rear Shroud (#18) to the Weight Stack Frame ASSY (#1) and the Top Bracket ASSY (#10) using:  
four M6\*20 CRPHS (#37)
4. Attach the Top Cover (#16) to the Weight Stack Frame ASSY (#1) using:  
two M6\*20 CRPHS (#37)                      two Spout Plug  $\Phi$ 16.5\*6.88 (#32)
5. Attach the Cup Holder (#19) to the Weight Stack Frame ASSY (#1) using:  
two M6\*20 CRPHS (#37)

**Note: Wrench tighten bolts.**

# Assembly

STEP 6

## Full Shroud

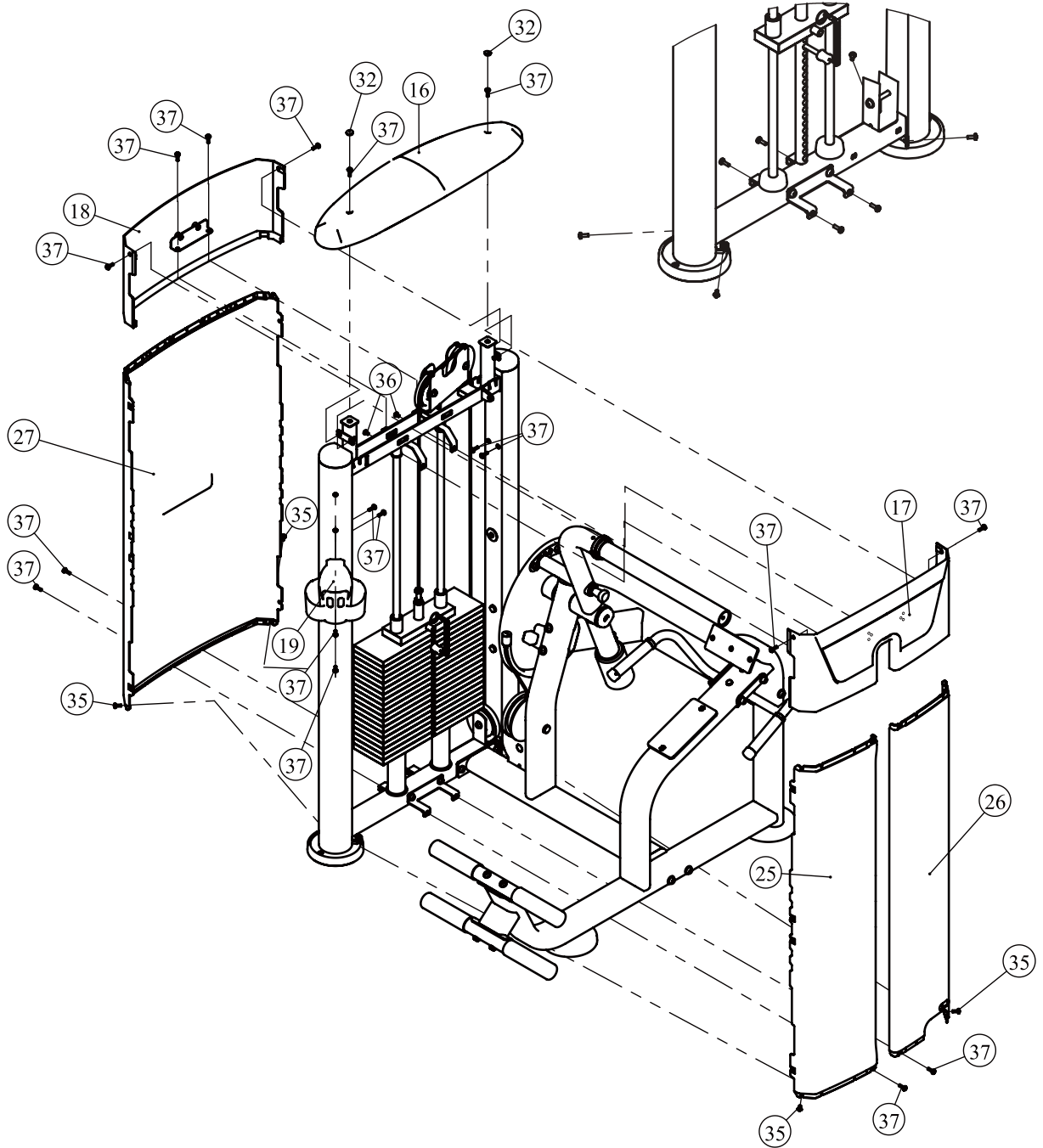

# Assembly

## STEP 6

## Half Rear Shroud

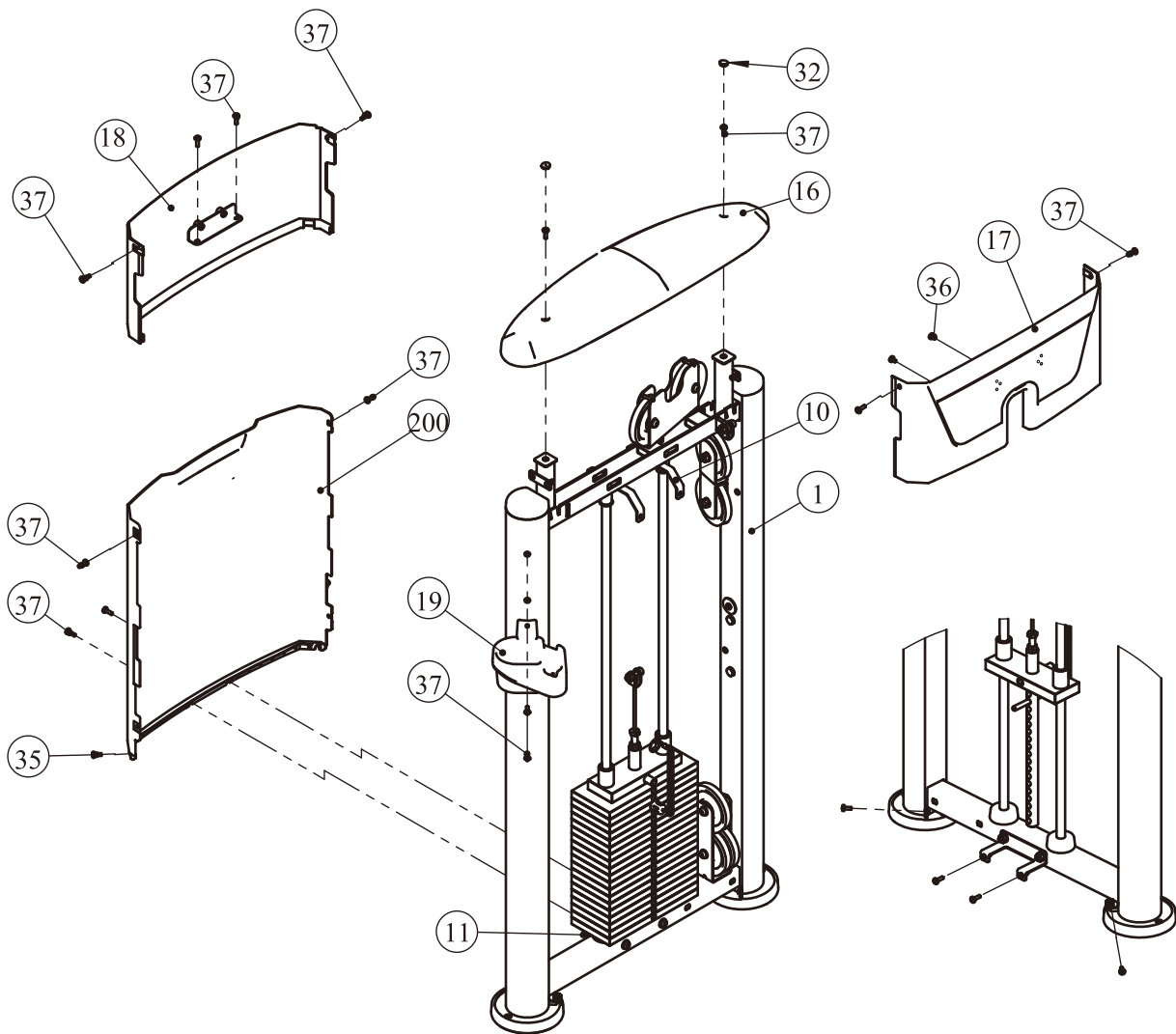

# Assembly

## STEP 7

1. Attach the Lumbar Pad (#24) to the Main Frame (#2) using:  
two M10\*30 SHCS (#55)  
two  $\Phi 11*\Phi 20*2$  Flat Washer (#49)
2. Attach the Seat Pad (#23) to the Main Frame (#2) using:  
two M10\*80 SHCS (#43)  
two  $\Phi 11*\Phi 20*2$  Flat Washer (#49)
3. Attach the FOAM ASSY (#22) to the Swing Frame ASSY (#5) using:  
one Plastic Ring (#56)  
one Cap  $\Phi 60$  (#34)  
one M10\*25 SHCS (#39)

**Note: Wrench tighten bolts and Nylon Lock Nuts.**

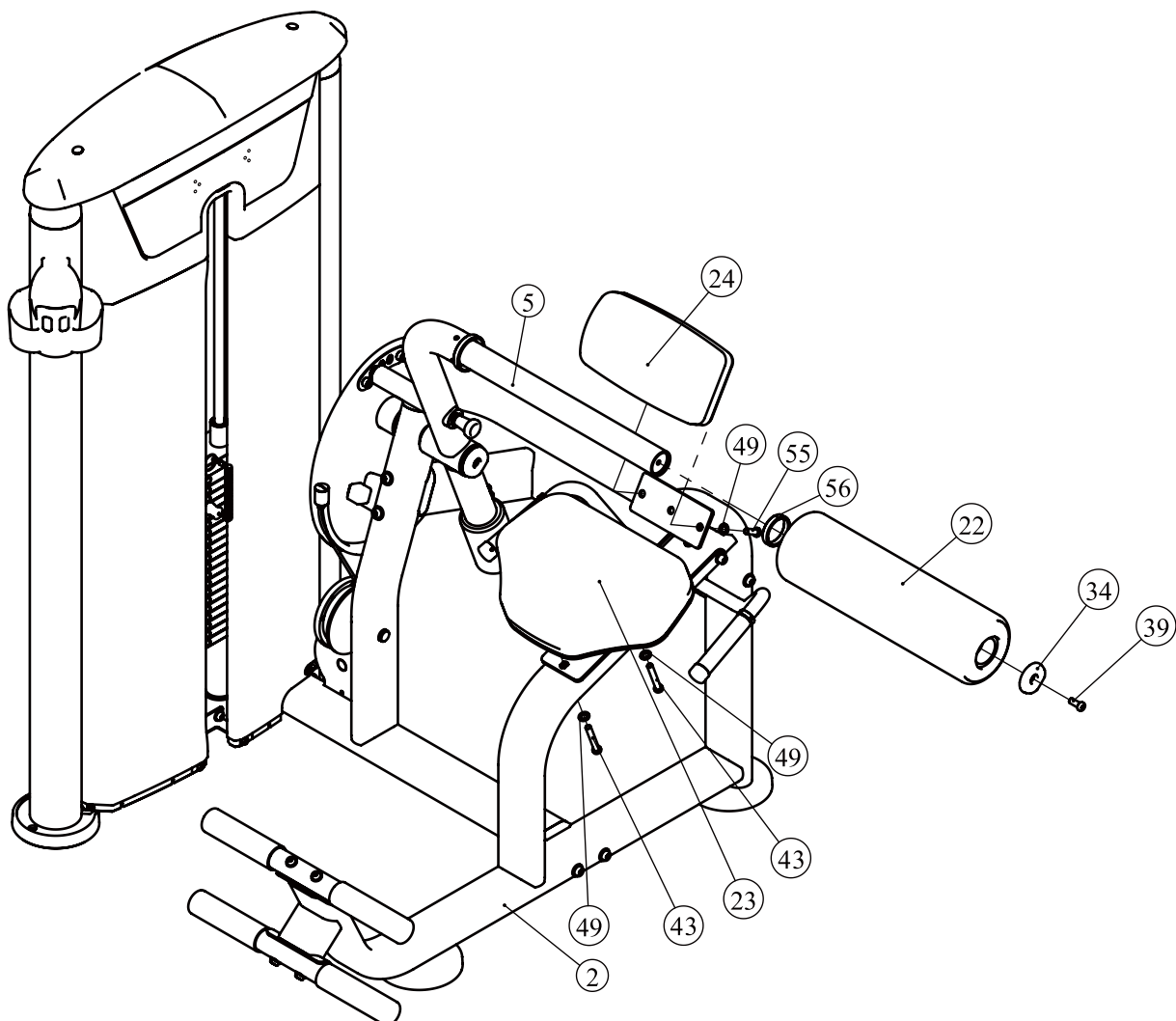

# Adjust Instructions

## The use of Selector Pin W/Coil

1. Select an appropriate weight and put the Selector Pin W/Coil into the hole on it.
2. Make sure the Selector Pin W/Coil gets into the hole completely.

## The Foam ASSY adjustment

1. Pull the Long Pin and adjust the Foam ASS to the desired position.
2. Make sure the pin gets into the hole completely.

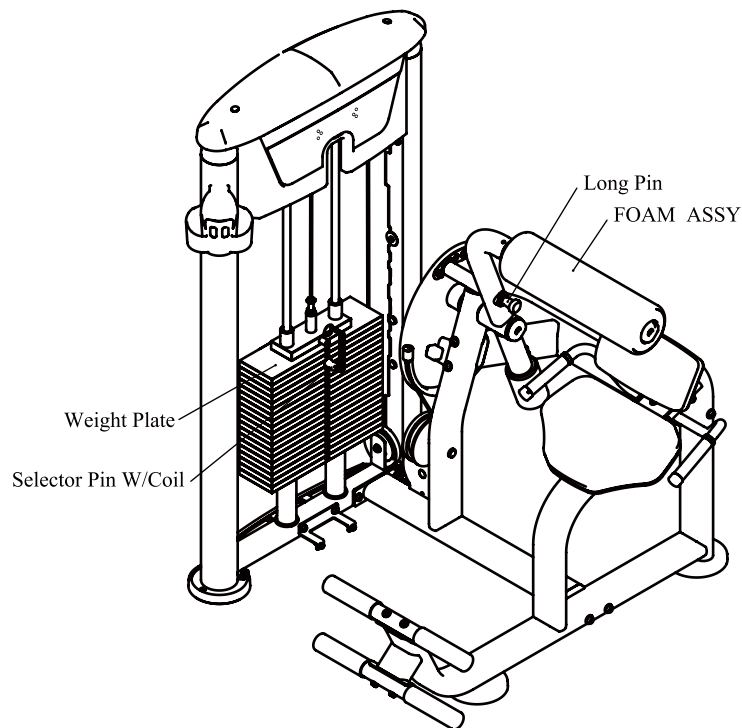

# Exercise Instructions

**BACK EXTENSION**

1. Select the appropriate weight.  
2. Adjust foam to the desired position.  
3. Put both feet on the foot plate and back against the roller. Then extend you back to the endpoint.  
4. Slowly return to the starting position.

Start Finish

The exercise instructions section is set against a dark grey background. On the left, there is a small diagram of the machine with a line pointing to the weight stack. Below this is a human figure with the back and core muscles highlighted in orange. To the right, two smaller diagrams show the 'Start' and 'Finish' positions of the exercise, with the person's back extended against the roller. The text 'BACK EXTENSION' is written in large, bold, white letters at the top right. Below it, the words 'Start' and 'Finish' are written above their respective diagrams.

# Maintenance Schedule

ROUTINE	COMMERCIAL MAINTENANCE	HOME MAINTENANCE	LATEST DATE ENTRY						
Inspect; Links, Pull Pins, Snap Locks, Swivels, Weight Stack Pins	DAILY	WEEKLY							
Clean; Upholstery	DAILY	WEEKLY							
Inspect; Cables or Belts and their tension	DAILY	WEEKLY							
Inspect; Accessory Bars, and Handles	WEEKLY	3 MONTHS							
Inspect; All Decals	WEEKLY	3 MONTHS							
Inspect; All Nuts and Bolts, Tighten if needed	WEEKLY	3 MONTHS							
Inspect; Anti-Skid Surface	WEEKLY	3 MONTHS							
Clean & Lubricate; Guide Rods with a Teflon (PTFE) based lubricant (Superlube)	MONTHLY	3 MONTHS							
Lubricate; Seat Sleeves, Turcite Bushings, Linear Bearing	MONTHLY	3 MONTHS							
Clean and Wax; All Glossy Finishes	6 MONTHS	YEARLY							
Repack with Grease; Linear Bearings	6 MONTHS	YEARLY							
Replace; Cables, Belts and Connecting Parts	YEARLY	3 YEARS							

*Your equipment comes with a commercial maintenance decal. For personal, in home use, please follow the home maintenance schedule listed above.*

# General Maintenance Information

## **Links, Pull-Pins, Snap Hooks, Swivels, Weight Stack Pins:**

- \* Check all pieces for signs of visible wear or damage.
- \* Check springs in snap hooks and pull-pins for proper tension and alignment.
- \* If the spring sticks or has lost its rigidity, replace it immediately.

## **Upholstery:**

- \* To ensure prolonged upholstery life and proper hygiene, all upholstered pads should be wiped down with a damp cloth after every workout.
- \* Periodically take the time to use a mild soap or an approved vinyl upholstery cleaner to deter the onset of cracking or drying. Avoid using any abrasive cleaners or cleaners not intended for use on vinyl.
- \* Replace ripped or worn upholstery immediately.
- \* Keep sharp or pointed objects clear of all upholstery.

## **Decals:**

- \* Inspect and familiarize yourself with any safety warnings or other user information posted on each decal.

## **Nuts and Bolts:**

- \* Inspect all nuts and bolts for any loosening and tighten if needed.
- \* Go through a re-tightening sequence periodically to ensure that all hardware is tensioned proper.

## **Anti-Skid Surfaces:**

- \* These surfaces are designed to supply secure footing and need to be replaced if they appear worn or become slippery.

## **Belts and Cables:**

- \* We use only high quality belt, and mil-spec cables.
- \* Visually inspect the belts and cables for fraying, cracking, peeling or discoloration.
- \* While the machine is not in use, carefully run your fingers along the belt or cable to feel for thinning or bulging areas.
- \* Replace belts and cables immediately at the first signs of damage or wear. Do not use equipment until belts or cables have been replaced.

## **Belt and Cable Tension:**

- \* Referring to the Owners Manual, when belts or cables are used check all bolt attachments to be sure they are properly attached.
- \* Check slack in cables and re-adjust cable tension if needed.

## **Seat Sleeves, Guide Rods:**

- \* Wipe down adjusting tubes with a dust free rag before applying lubricant.
- \* Lubricate seat sleeves and Guide Rods with a Silicon or Teflon based lubricant spray.

## **Linear Bearings:**

- \* Referring to the Owners Manual carefully disassemble the bearing from its housing and place a finger full of light grease (lithium, super lube, etc.) into the inside of the bearing. Using your finger, press the grease into the ball-bearings and their tracks. Repeat until the ball-bearing tracks are full of grease. Insert the shaft back into the bearing and wipe off excess grease.

**PLEASE KEEP THIS FOR YOUR RECORDS**

## Weight Training Tips

Use this manual to guide you through the basic exercises you can perform on your equipment. To gain maximum results and avoid possible injury, consult a fitness professional to develop your complete exercise program.

Always consult your physician before starting any exercise program.

To be successful in your exercise program, it is important to develop an understanding of the basic principles of strength training. Now that you have your equipment, it is only natural that you want to get started immediately. First, determine a set of realistic goals and objectives for yourself. By deciding on an exercise plan that is right for you prior to starting, you will contribute significantly to your success.

Warm up properly before engaging in weight resistance training. Stretching, yoga, jogging, calisthenics or other cardiovascular exercise can help prepare your body for the heavier workload of lifting weights.

Learn how to perform the exercise correctly before using heavy weight. Correct form is important to avoid injury and to ensure that you work the proper muscle groups.

Know your limitations. If you are new to weight training or are embarking on an exercise regimen after a long layoff, start slowly and build foundational strength over a longer period of time.

Pay attention to your breathing. Exhale when you exert is a general rule of thumb. Never hold your breath.

