

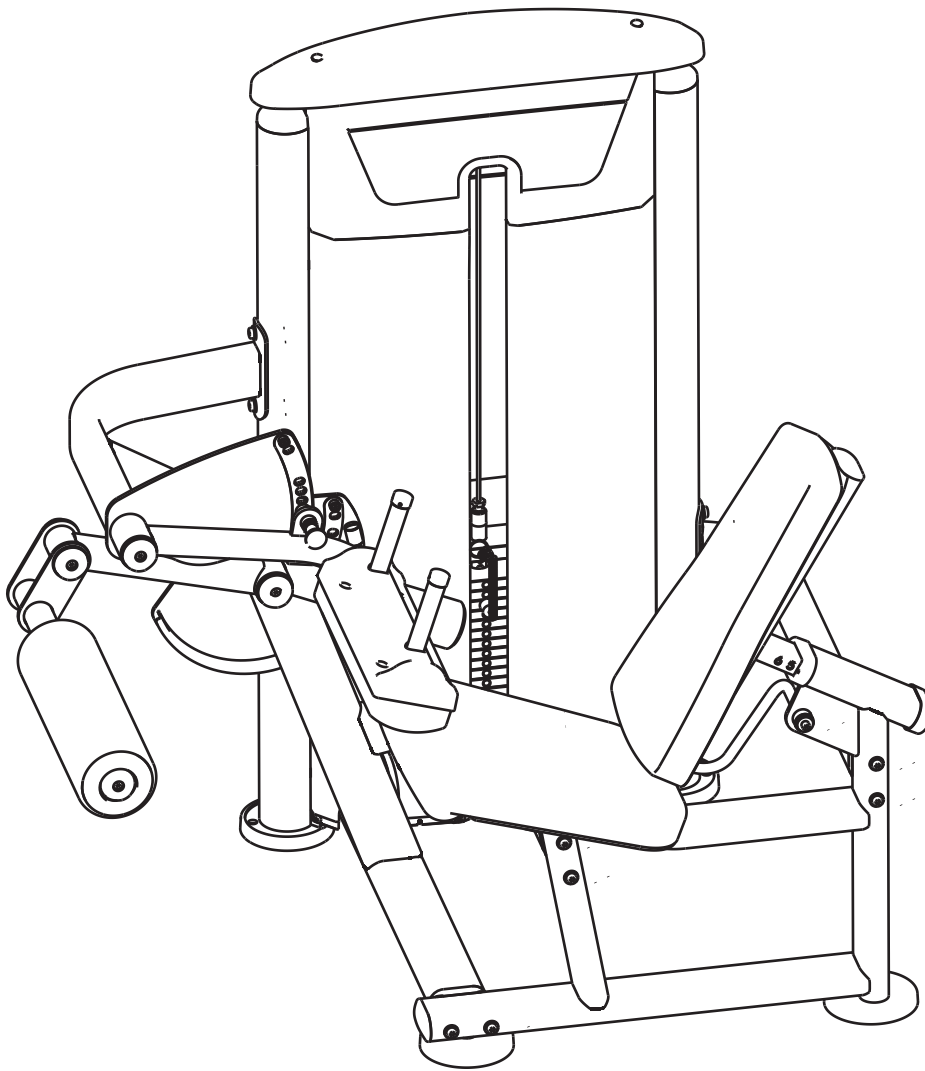

7012-G2

SEATED LEG CURL

Owner's Manual



! CAUTION

Read all precautions
and instructions in this manual
before using this equipment

Table Of Contents

CAUTION!

Read all precautions and instructions in this manual before using this equipment.

Important Safety Instructions-----	3
Instructions-----	5
Exploded View and Parts List-----	6
Measurement Guide-----	17
Assembly Instructions-----	18
Assembly-----	19
Adjust Instructions-----	34
Exercise Instructions-----	34
Maintenance Schedule-----	35
General Maintenance Information-----	36
Weight Training Tips-----	37

Please assemble according to the actual **Weights and Shroud** you buy !

Important Safety Instructions

Before beginning any fitness program, you should obtain a complete physical examination from your physician. When using exercise equipment, basic precautions should always be taken, including the following:

1. Read all instructions before using the equipment.
These instructions are written to ensure your safety and to protect the unit.
2. Use the equipment only for its intended purpose as described in this guide.
Do not use accessory attachments that are not recommended by the manufacturer: such attachments might cause injuries.
3. The product should only be used on a level surface and is with 0.6 meters space around the product.
Do not use the equipment outdoors.
4. Do not allow children on or near the equipment. And children are not allowed to use this equipment.
Teenagers should use this equipment with adult supervision.
5. Do not overexert yourself or work to exhaustion.
Do not attempt to lift more weight than you can control safely.
If you feel any pain or abnormal symptoms, stop your workout immediately and consult your physician.
6. This equipment is not used as medical apparatus and instruments.
7. Never operate the unit when it has been dropped or damaged.
Never drop or insert anything into any opening in the equipment.
Always check the unit and its cables before each use. Make sure that all fasteners and cables are secure and in good working condition.
Frayed or worn cables can be dangerous and may cause injury. Periodically check these cables for any indication of wear.
Keep hands, limbs, loose clothing and long hair well out of the way of moving parts.
8. Be careful when getting on or off the equipment.
9. Wear proper exercise clothing and shoes for your workout, no loose clothing.

Important Safety Instructions

Personal Safety During Assembly

Read each step in the assembly instructions and follow the steps in sequence. Do not skip ahead. If you skip ahead, you may learn later that you have to disassemble components and that you may have damaged the equipment.

Assemble and operate the equipment on a solid, level surface. Locate the unit a few feet from walls or furniture to provide easy access. The equipment is designed for your enjoyment. By following these precautions and using common sense, you will have many safe and pleasurable hours of healthful exercise with the equipment.

Training Area and Free Area

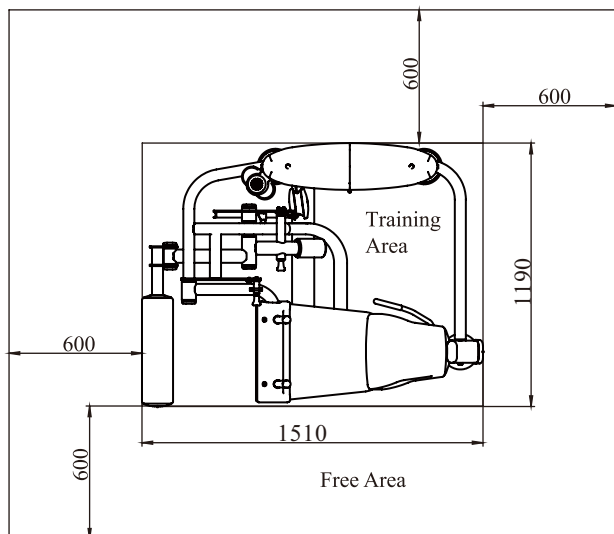

Specifications

Class: S

Maximum Wt. Capacity: 134kg/ 295lbs

Maximum User Weight: 150kg/ 330lbs

Product Dimension: 1510*1190*1510mm

Product Total Surface: 1510*1190mm

Product Total Mass: 149.6kg/ 330lbs

Instructions

Before beginning assembly please take the time to read instructions thoroughly. Please use the various lists in this manual to make sure that all parts have been included in your shipment. When ordering, use part number and description from the lists. Use only our replacement part when servicing. Failure to do so will void your warranty and could result in personal injury.

The equipment is designed to provide the smoothest, most effective exercise motion possible. After assembly, you should check all functions to ensure correct operation. If you experience problems, first recheck the assembly instructions to locate any possible errors made during assembly. If you are unable to correct the problem, call your authorized dealer. Be sure to have your serial number and this manual when calling. When all parts have been accounted for, continue on.

Tools Required

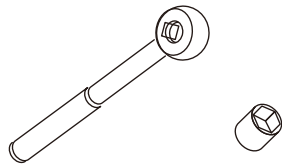

Ratchet Wrench and Socket

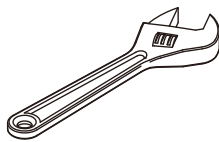

Adjustable Wrench

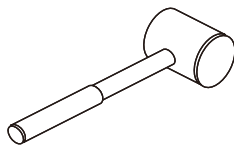

Rubber Mallet

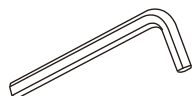

Hex Key Wrench Set

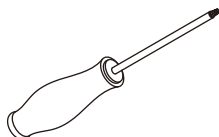

Phillips Screwdriver

Exploded View and Parts List

Overall

Item No.	Grade No.	Part No.	Description	QTY
1	1	IT950601ASSY	Weight Stack Frame ASSY	1
2	2	IT950602ASSY	Main Frame ASSY	1
3	3	IT95060300	Rear Connection Frame	1
4	4	IT950604ASSY	Front Support Frame ASSY	1
5	5	IT95060500	FOAM Frame	1
6	6	IT950606ASSY	Thigh Frame ASSY	1
7	7	IT950607ASSY	Swing Frame ASSY	1
8	8	IT950608ASSY	Wheel Frame ASSY	1
9	9	IT950508ASSY	Back Pad Frame ASSY	1
10	10	IT950510ASSY	Adjustable Handle Frame ASSY	1
11	11	CWRVL0101100	Plate	1
12	12	SD1000B3000ASSY	Adjustable Foot Plate	2
13	13	SG500110400V5	4.5" Pulley	3
14	14	V37000	V-type Pulley	1
15	16	IT95016000	Plastic Cover	3
16	17	IT95016400	Pulley Cover	2
17	21	IT950121ASSY	Top Bracket ASSY	1
18	22	IT950122ASSY	Bottom Bracket ASSY	2
19	23	IT95012300	Rear Bracket	1
20	42	IT95014200	Top Plate	1
21	44	IT95014400	Guide Rod $\Phi 19 \times 1242$	2
22	51	IT95015100	Top Cover	1
23	52	IT95015200	Training Placard Cover	1
24	53	IT95015300	Front Shroud	1
25	54	IT95055400	Left Front Shroud	1
26	55	IT95015500	Top Rear Shroud	1
27	56	IT95015600	Rear Shroud	1
28	71	IT950171ASSY	Back Pad ASSY	1
29	75	IT95067500	Cable ASSY	1
30	76	IT95057600	Seat Pad	1
31	77	IE950528ASSY	FOAM ASSY	1
32	78	IT95067600	Thigh Pad	1
33	79	IT95067300	Thigh Pad Shroud	1
34	92	IT95016600	Cup Holder	1

Exploded View and Parts List

Overall

Item No.	Grade No.	Part No.	Description	QTY
35	101	FE97211900	Cap Φ 60	3
36	102	FE97212000	Circle Ring Φ 62.5*5	2
37	103	IT80023000	Weight Rubber Bumper	2
38	104	IT90012000V1	Selector Pin W/Coil	1
39	106	IT95016100	Guide Rod Fixing Sleeve Φ 25* Φ 19*45	2
40	107	IT95016500	Spout Plug Φ 16.5*6.88	2
41	108	HFOPT900-04A0602	Spring	2
42	109	V22500	Plug	1
43	110	HFOPT900-04A1400	Aluminium Sheath	1
44	111	GB894.125FH12	Circlips For Shaft	1
45	112	GB70BTM12*135DN18NL	Socket Head Cap Screw M12*135	6
46	113	GB70BTM12*30DN18NL	Socket Head Cap Screw M12*30	4
47	114	GB70BTM10*70DN18	Socket Head Cap Screw M10*70	1
48	115	GB70BTM10*80DN18	Socket Head Cap Screw M10*80	4
49	116	GB70BTM10*75DN18	Socket Head Cap Screw M10*75	2
50	117	GB70BTM10*50DN18	Socket Head Cap Screw M10*50	3
51	118	GB70BTM10*30DN18	Socket Head Cap Screw M10*30	9
52	119	GB70BTM10*25DN18	Socket Head Cap Screw M10*25	6
53	120	CNLM10*25DS20	Flat Head Cap Screw M10*25	2
54	121	GB70M8*20N19	Socket Head Cap Screw M8*20	3
55	122	GB818M6*20DHS2	Cross Recessed Pan Head Screw M6*20	18
56	123	GB818M6*16DHS2	Cross Recessed Pan Head Screw M6*16	4
57	124	GB818M6*10DHS2	Cross Recessed Pan Head Screw M6*10	4
58	125	NM10DN2	Nylon Lock Nut M10	10
59	126	DQ8DS2B	Flat Washer Φ 9* Φ 28*2	1
60	127	GB9512DN2	Flat Washer Φ 13* Φ 24*2.5	10
61	128	GB9510DN2	Flat Washer Φ 11* Φ 20*2	22
62	129	GB958DN2	Flat Washer Φ 9* Φ 16*1.6	2
63	130	IT95062400V1	Shaft	1
64	131	IT95062000	Cap ASSY	3
65	132	NBS6DHS	Hex Key S=6	1
66	133	NBS8DHS	Hex Key S=8	1
67	134	LW200BS	Wrench Φ 6*117	1
68	135	YHY	Lube	1
69	300	IF93062200	Big Washer Φ 62* Φ 10.5*3	2
200	200	IT9501C3100	Half Rear Shroud	1

Exploded View and Parts List

Overall

Full Shroud

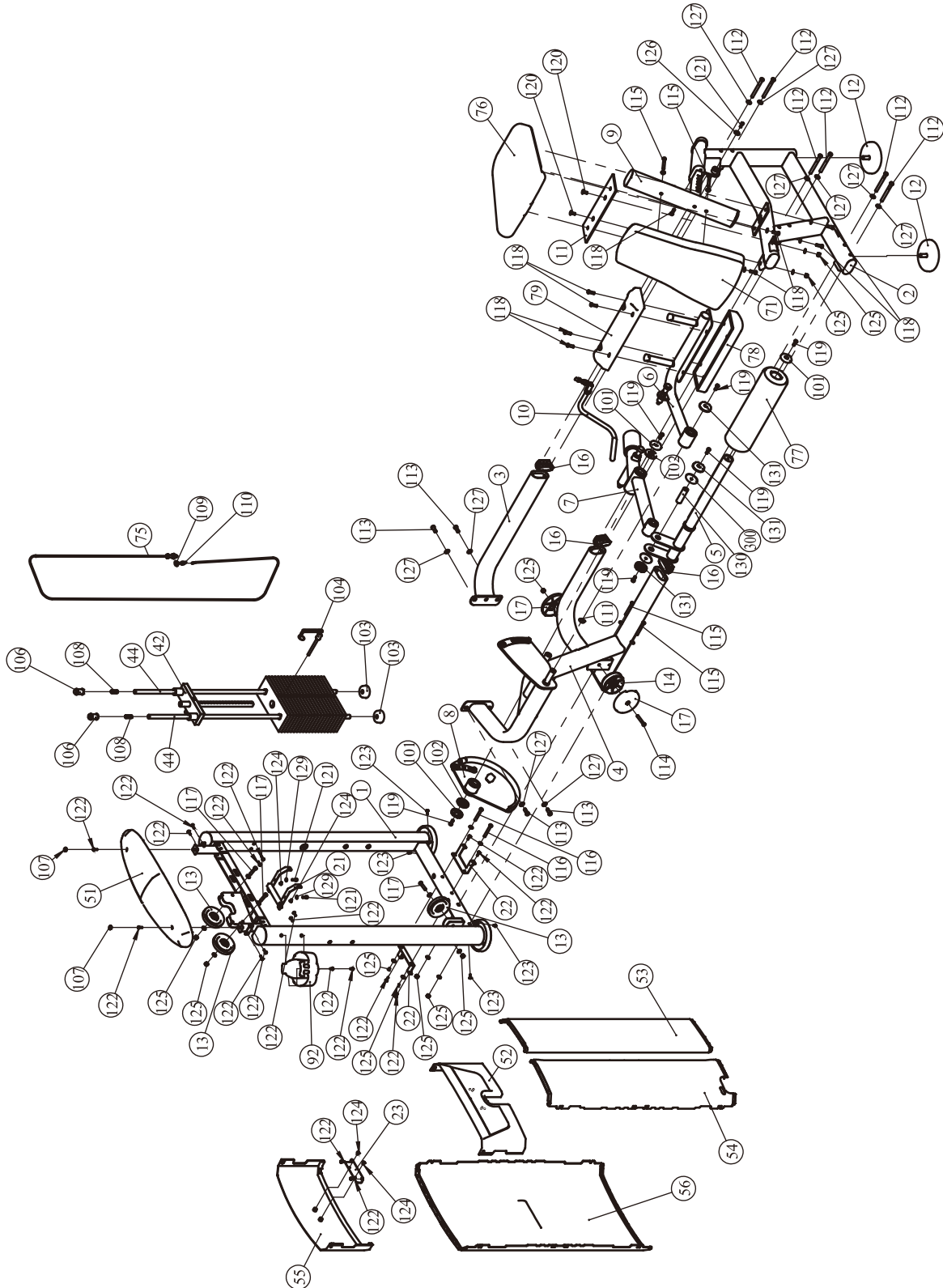

Exploded View and Parts List

Overall

Half Rear Shroud

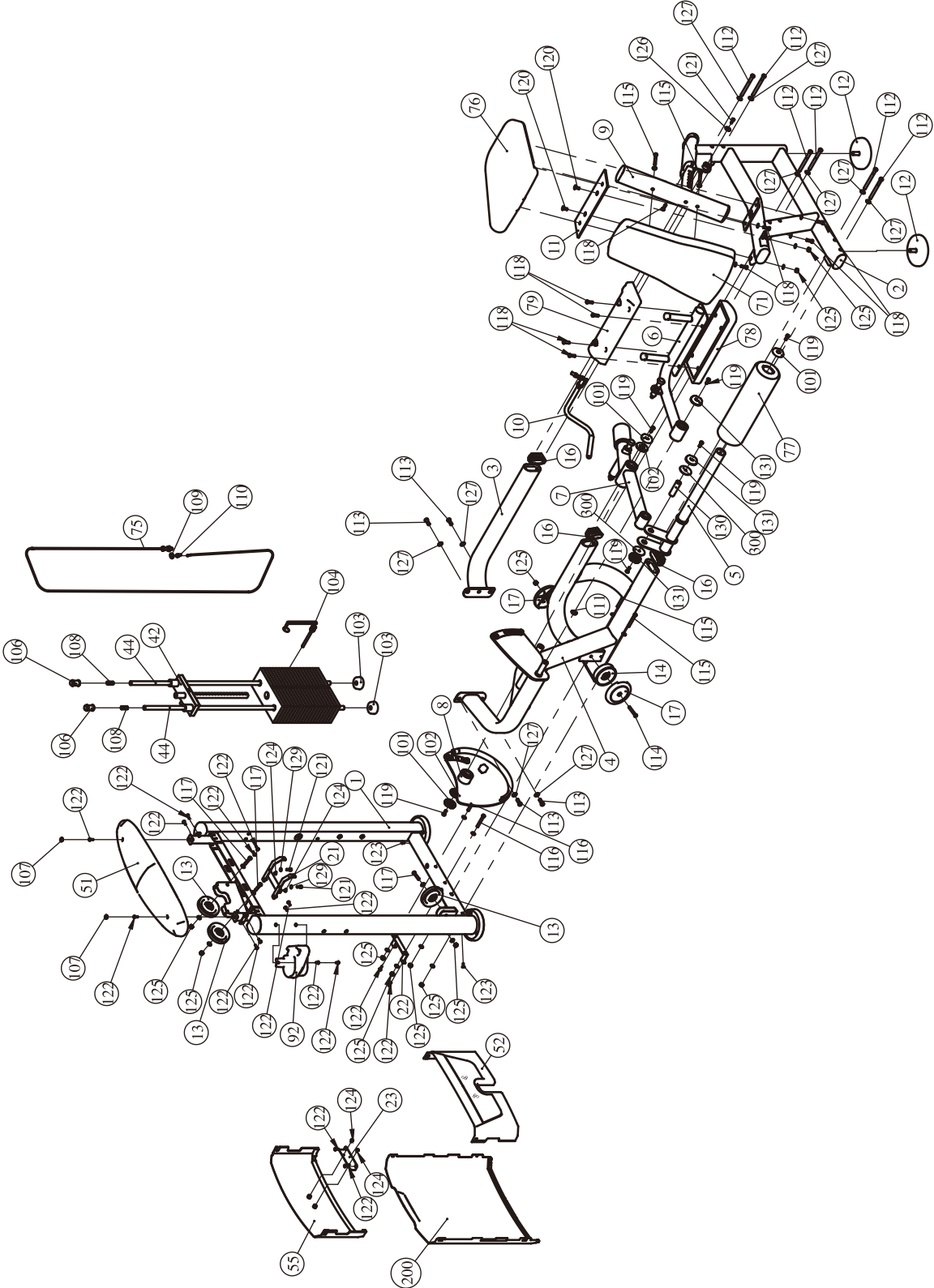

Exploded View and Parts List

Weight Stack Frame ASSY

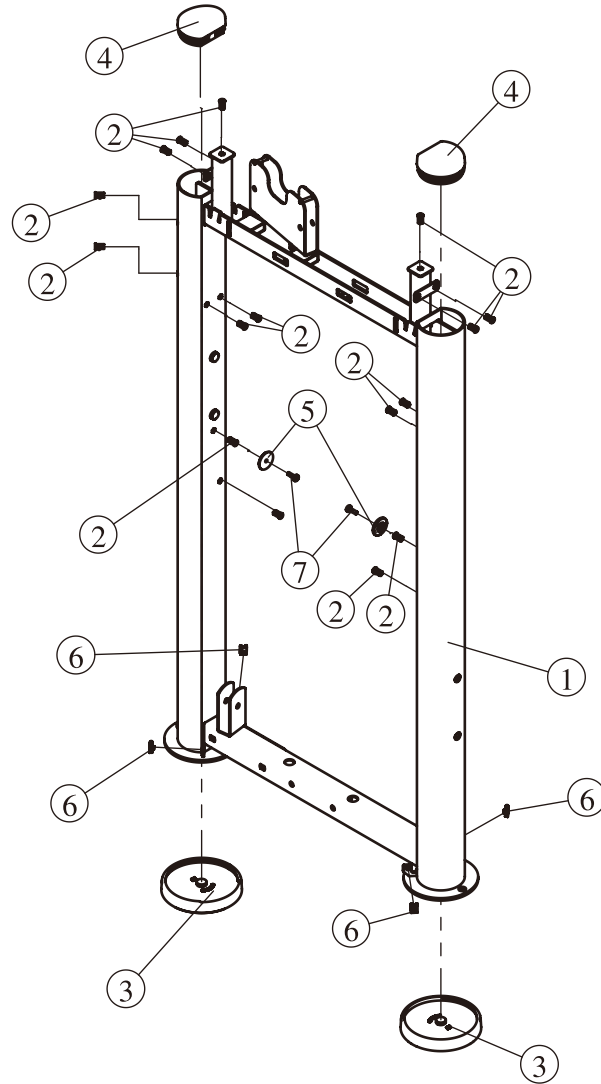

Item No.	Grade No.	Part No.	Description	QTY
1	1.1	IT95060100	Weight Stack Frame	1
2	1.2	GB17880.5M6*16.5DS17	Rivet Nut M6	16
3	1.3	IT95015700	Foot Plate	2
4	1.4	IT95015800	Plug $\Phi 95 \times 81.1$	2
5	1.5	IT95015900	Plastic Block	2
6	1.6	AC32705800	U-nut M6	4
7	1.7	GB818M6*20DHS2	Cross Recessed Pan Head Screw M6*20	2

Exploded View and Parts List

Main Frame Sub ASSY

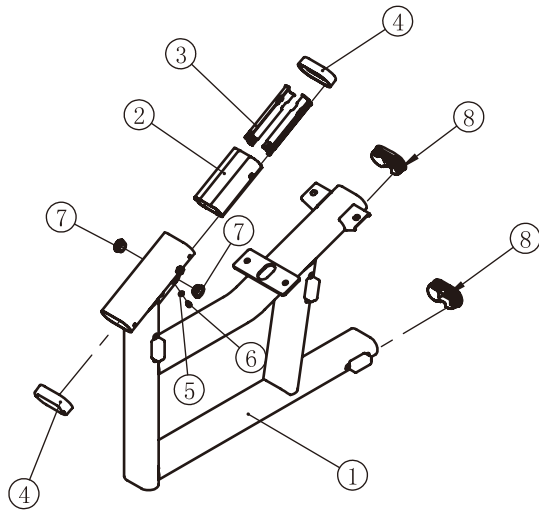

Front Support Frame ASSY

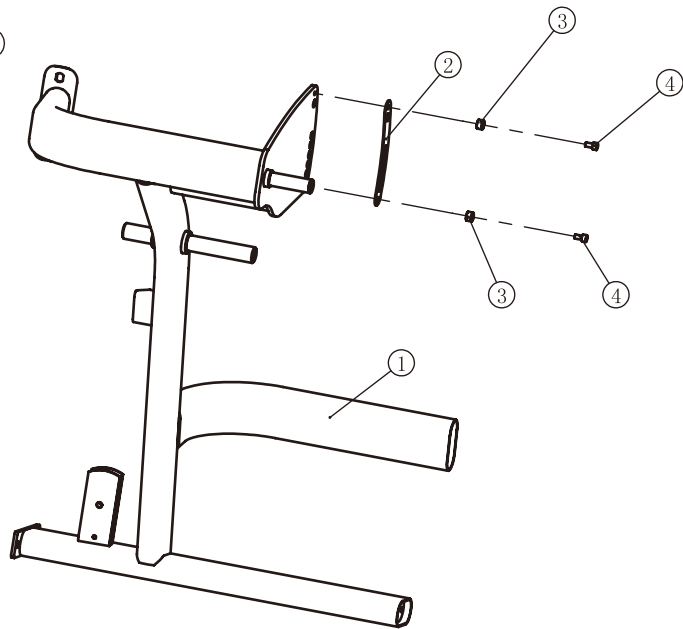

Item No.	Grade No.	Part No.	Description	QTY
1	2.1	IT95060200	Main Frame	1
2	2.2	IT95054300	Aluminum Tube Guide	1
3	2.3	IT95016300	Plastic Corner Tube Glide	4
4	2.4	IT95016200	Plastic Tube Plug	2
5	2.5	GB956DN2	Flat Washer $\Phi 6.6 * \Phi 12 * 1.6$	1
6	2.6	GB70M6*10N 19	Socket Head Cap Screw M6*10	1
7	2.7	HVCORE5300	Bushing $\Phi 19$	2
8	2.8	IT90013800P11C	Plug RT50*100	2

Item No.	Grade No.	Part No.	Description	QTY
1	4.1	IT95060400	Front Support Frame	1
2	4.2	IT95062300	Lining Board 1	1
3	4.3	IN-S10111200	Rubber Sleeve $\Phi 17 * 10.5$	2
4	4.4	GB70M8*15N 19NL	Socket Head Cap Screw M8*15	2

Exploded View and Parts List

Thigh Frame ASSY

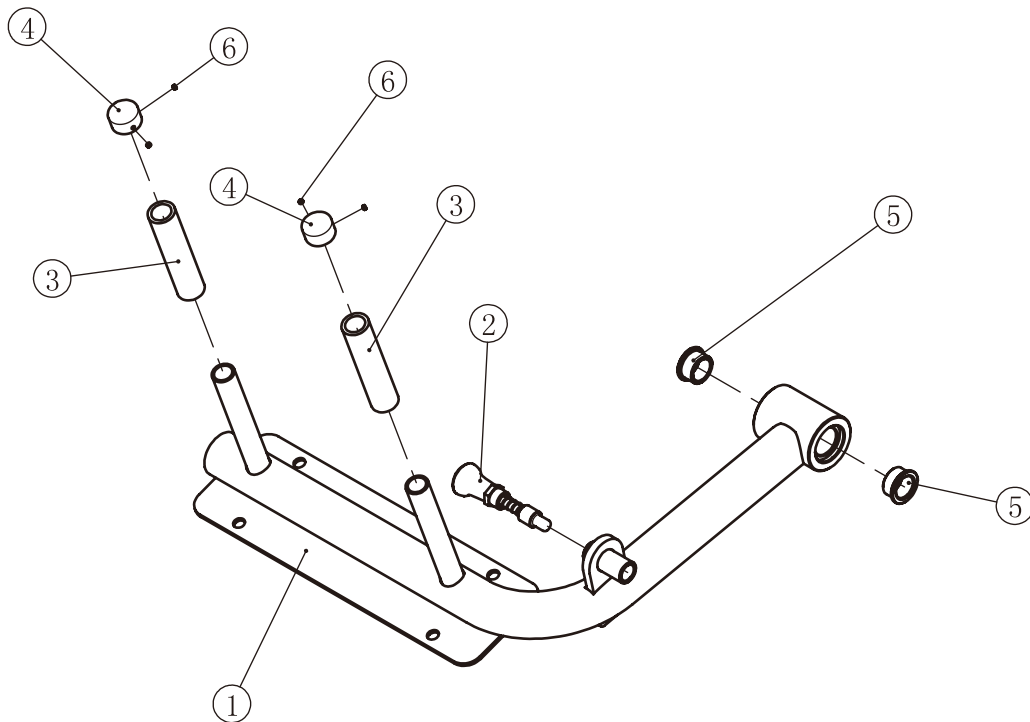

Item No.	Grade No.	Part No.	Description	QTY
1	6.1	IT95060600	Thigh Frame	1
2	6.2	IT95021600	Long Pin	1
3	6.3	FE97031800	Grip	2
4	6.4	V39600	Aluminum Grip Cap	2
5	6.5	M02502000	Spacer Φ 38* Φ 32* Φ 25.4*18	2
6	6.6	YZGB7710-32*3.2N19	Socket Set Screw 10-32UNF*3.2	4

Exploded View and Parts List

Swing Frame ASSY

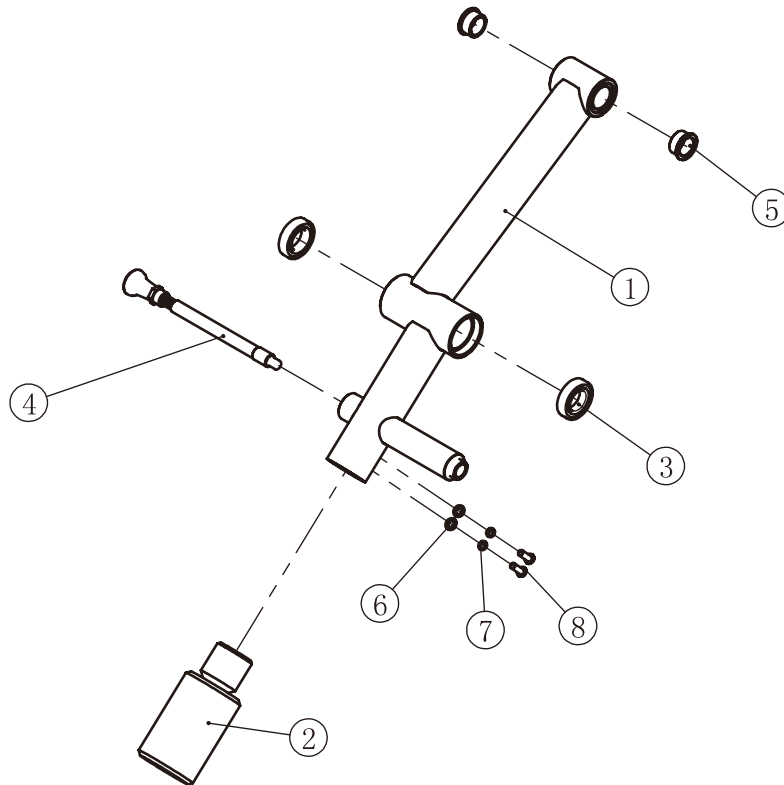

Item No.	Grade No.	Part No.	Description	QTY
1	7.1	IT95060700	Swing Frame	1
2	7.2	IT95121200	Counter Poise Block	1
3	7.3	GB2766006-2RSC3NBK	Bearing	2
4	7.4	IT950521ASSY	Long Pin	1
5	7.5	M02502000	Spacer Φ 38* Φ 32* Φ 25.4*18	2
6	7.6	GB958DN2	Flat Washer Φ 9* Φ 16*1.6	2
7	7.7	GB938N19	Spring Washer Φ 8	2
8	7.8	PNLM8*25DN20	Button Head Cap Screw M8*25	2

Exploded View and Parts List

Wheel Frame ASSY

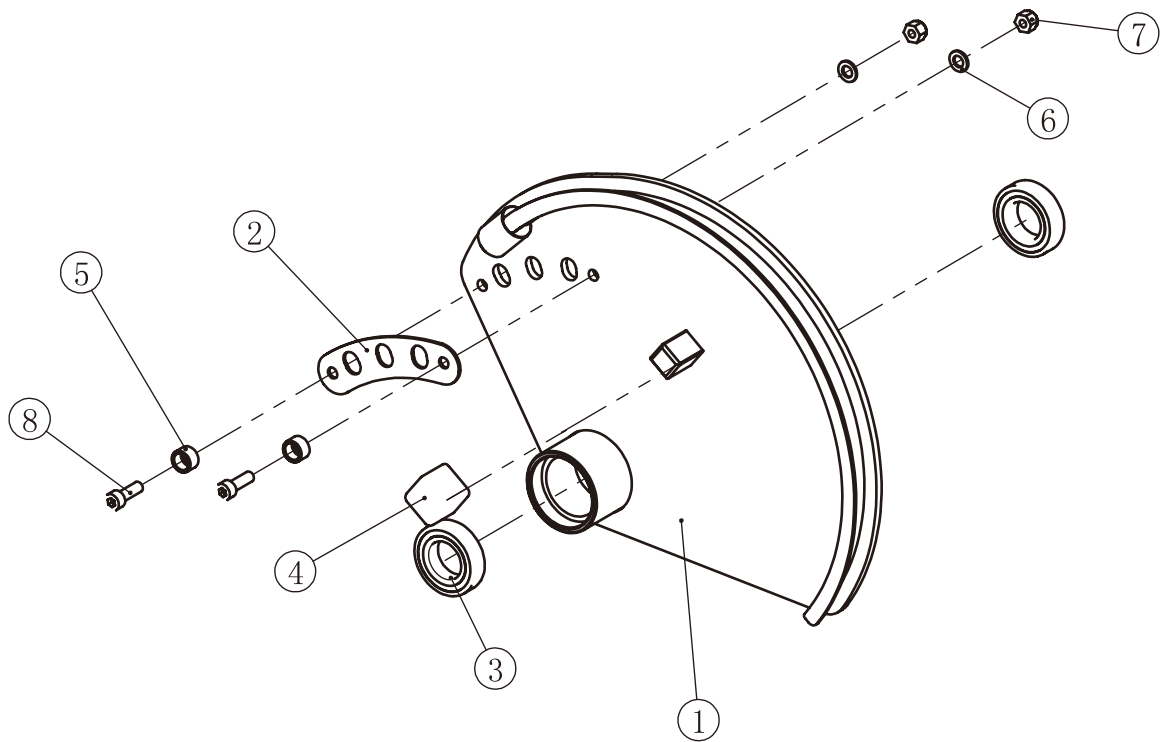

Item No.	Grade No.	Part No.	Description	QTY
1	8.1	IT95060800	Wheel Frame	1
2	8.2	IT95062500	Lining Board 2	1
3	8.3	GB2766006-2RSC3NBK	Bearing	2
4	8.4	FE97213100	Square Rubber Sleeve	1
5	8.5	IN-S10111200	Rubber Sleeve $\Phi 17*10.5$	2
6	8.6	GB958DN2	Flat Washer $\Phi 9*\Phi 16*1.6$	2
7	8.7	NM8DN2	Nylon Lock Nut M8	2
8	8.8	GB70M8*20DS20	Socket Head Cap Screw M8*20	2

Exploded View and Parts List

Back Pad Frame ASSY

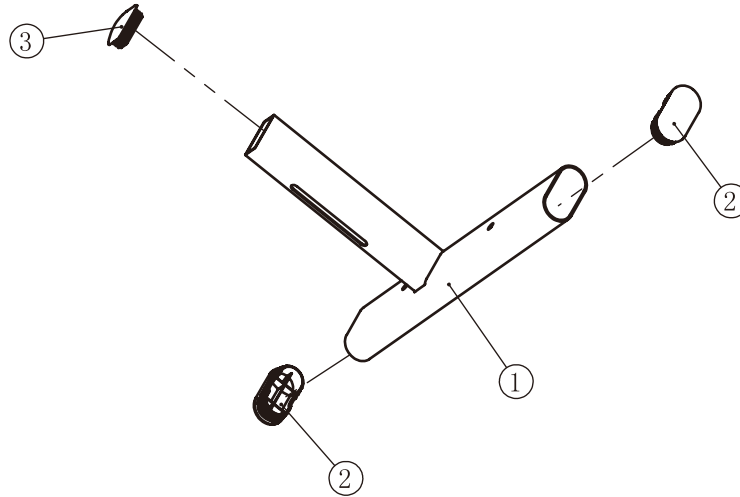

Item No.	Grade No.	Part No.	Description	QTY
1	9.1	IT95050800	Back Pad Frame	1
2	9.2	IT90013800P11C	Plug RT50*100	2
3	9.3	IN-D10134200P11C	Plug □30*70	1

Adjustable Handle Frame ASSY

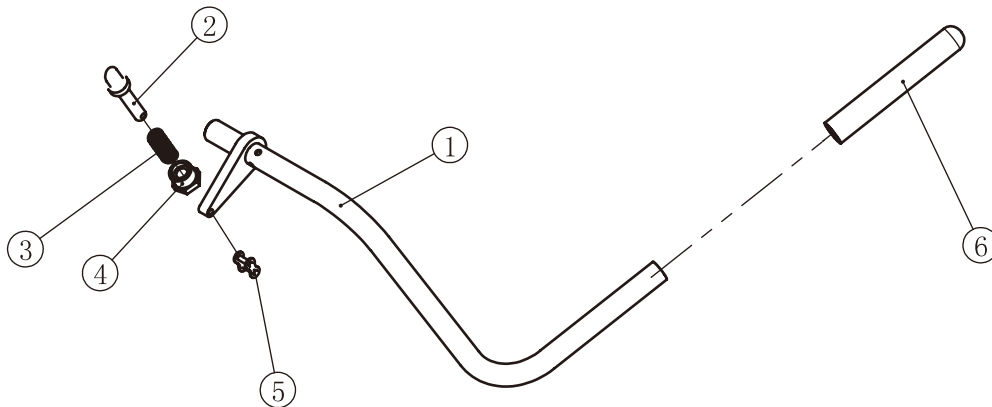

Item No.	Grade No.	Part No.	Description	QTY
1	10.1	IT95100700	Adjustable Handle Frame	1
2	10.2	IT95052400	Pin	1
3	10.3	IN-B72001600	Spring	1
4	10.4	KPS18002701V1	Nut M20*1.5*18	1
5	10.5	GB/T1243-199708BN19	Chain	1
6	10.6	FS522800	Grip	1

Exploded View and Parts List

Back Pad ASSY

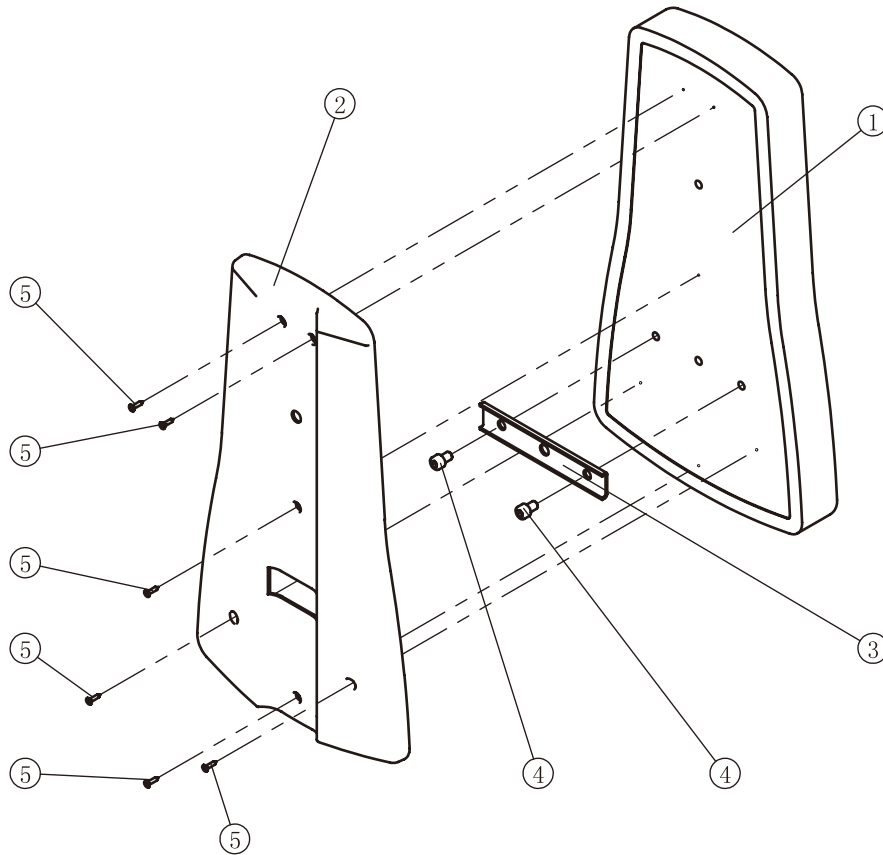

Item No.	Grade No.	Part No.	Description	QTY
1	71.1	IT95017100	Back Pad	1
2	71.2	IT95017300	Back Pad Cover	1
3	71.3	IT95017500	Back Pad Support Plate	1
4	71.4	GB70M10*15DS20	Socket Head Cap Screw M10*15	2
5	71.5	GB846ST4.2*19DHS	Cross Recessed Countersunk Head Tapping Screw ST4.2*19	6

Measurement Guide

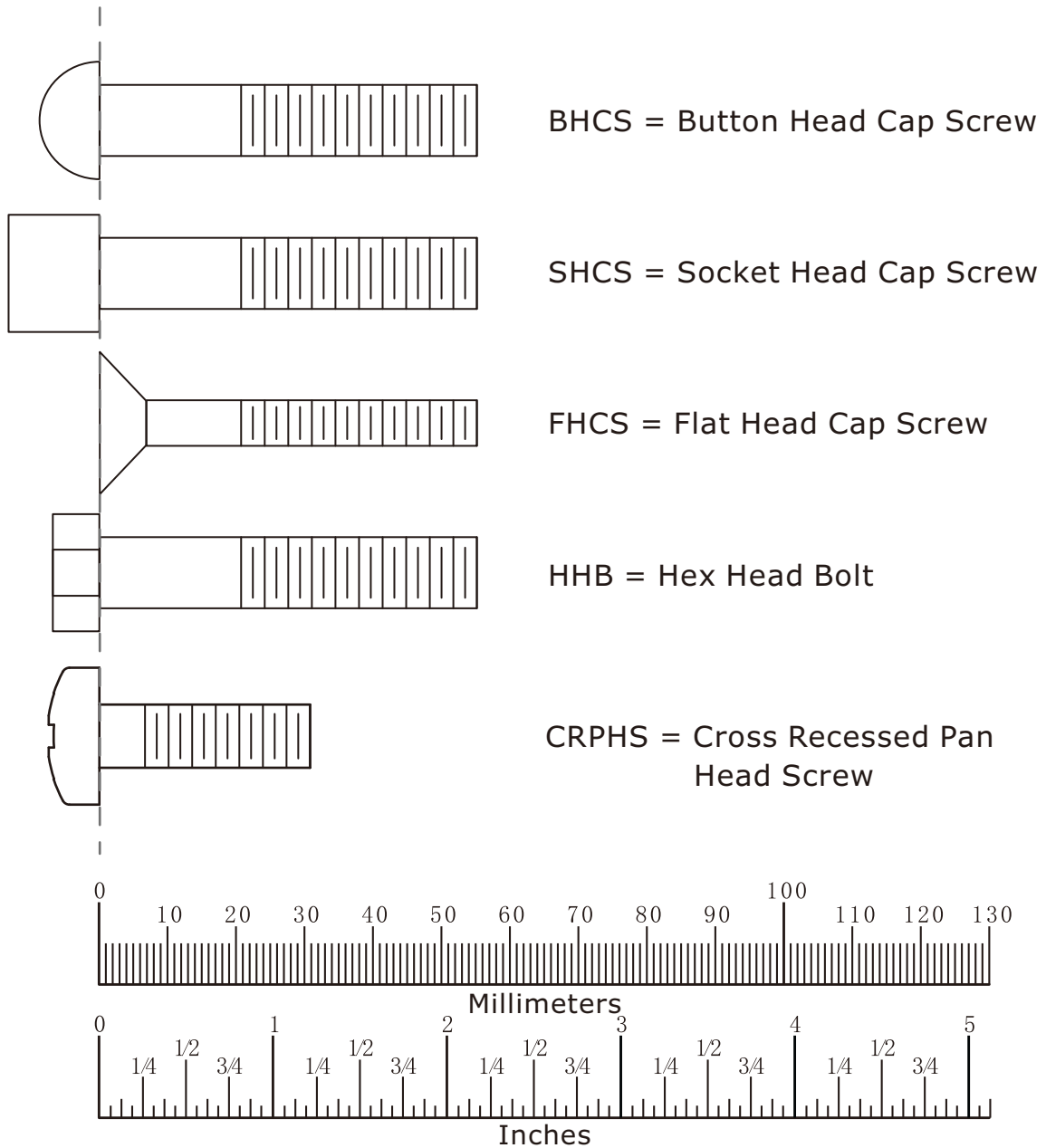

Diameter of bolt (mm/inch)	M6(1/4")	M8(5/16")	M10(3/8")	M12(1/2")	M16(5/8")
Tightening torque (N.m)	9~12	22~30	45~59	78~104	193~257
Operational methods for adult men	The strength of the wrist	The strength of the wrist and forearm	The strength of the entire arm	The strength of the arm and upper body	with all strength

Assembly Instructions

Assembly of the equipment takes professional installers about 2 hours. If this is the first time you have assembled this type of equipment, plan to spend more time. It is strongly recommended to assemble the equipment by professional installers. You may find it quicker, safer, easier to assemble this equipment with the help of a friend, as some of components may be large, heavy or awkward to handle alone. It is important that you assemble your product in a clean, clear, uncluttered area. This will enable you to move around the product while you are fitting components and reduce the possibility of injury during assembly.

NOTE

As with any assembled part, proper alignment and adjustment is critical. While tightening the fasteners, be sure to leave room for adjustments. Do not fully tighten the fasteners until instructed to do so. Be careful to assemble the components in the sequence presented in this guide.

Assembly

STEP 1

1. Attach two Adjustable Foot Plates (#12) to the Main Frame ASSY (#2).
2. Attach the Rear Bracket (#23) to the Top Rear Shroud (#55) using:
two M6*10 CRPHS (#124)

Note: Wrench Tighten Bolts.

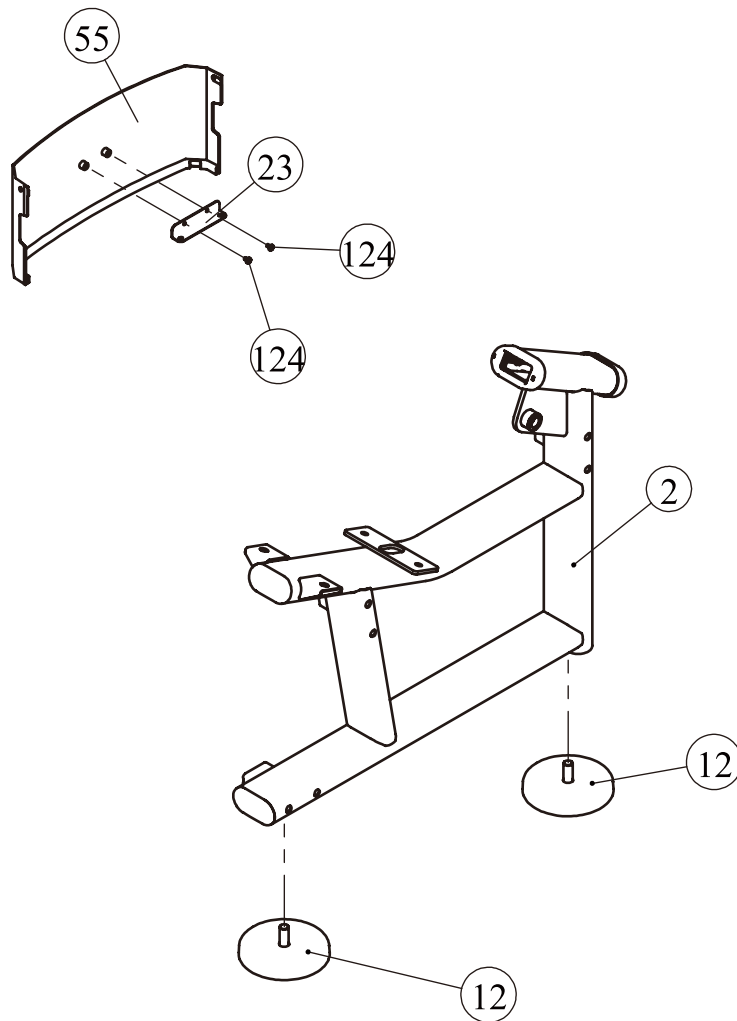

Assembly

STEP 2

Attach the Front Support Frame ASSY (#4) and the Rear Connection Frame (#3) to the Weight Stack Frame ASSY (#1) and the Main Frame ASSY (#2) using:

- three Plastic Cover (#16)
- six M12*135 SHCS (#112)
- four M12*30 SHCS (#113)
- two M10*80 SHCS (#115)
- two M10 Nylon Lock Nut (#125)
- four $\Phi 11*\Phi 20*2$ Flat Washer (#128)
- ten $\Phi 13*\Phi 24*2.5$ Flat Washer (#127)

Note: 1. Wrench Tighten Bolts and Nylon Lock Nuts.

2. Adjust the Adjustable Foot Plates to make the machines stable.

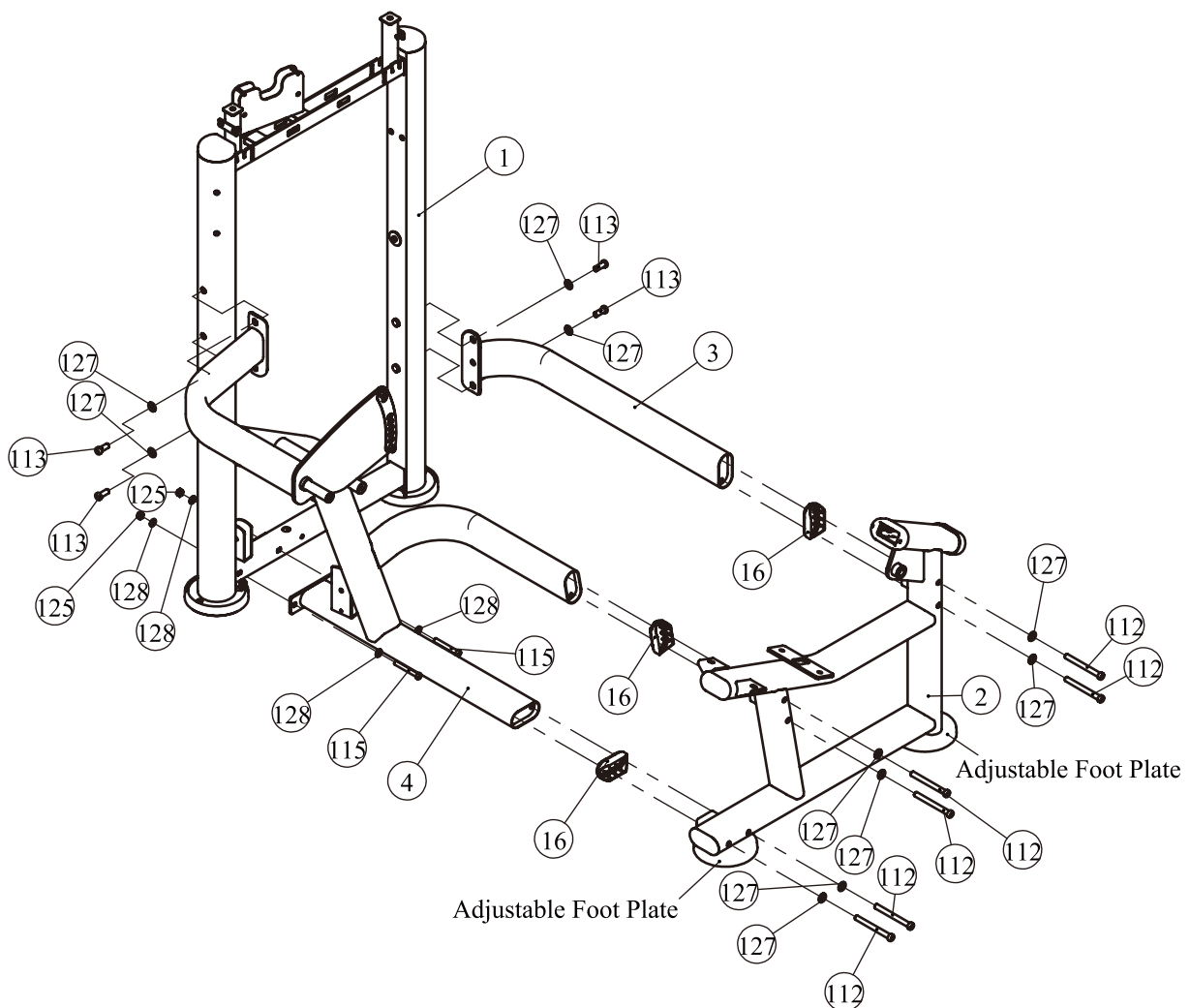

Assembly

STEP 3

1. Attach one 4.5" Pulleys (#13) to the Weight Stack Frame ASSY (#1) using:
 - one M10*50 SHCS (#117)
 - two $\Phi 11*\Phi 20*2$ Flat Washer (#128)
 - one M10 Nylon Lock Nut (#125)
2. Attach the Top Bracket ASSY (#21) and two/one Bottom Bracket ASSY (#22) to the Weight Stack Frame ASSY (#1) using:
 - two M8*20 SHCS (#121)
 - two $\Phi 9*\Phi 16*1.6$ Flat Washer (#129)
 - two M10*75 SHCS (#116)
 - four $\Phi 11*\Phi 20*2$ Flat Washer (#128)
 - two M10 Nylon Lock Nut (#125)
3. Attach the Wheel Frame ASSY (#8) and the Swing Frame ASSY (#7) to the Front Support Frame ASSY (#4) using:
 - two Cap $\Phi 60$ (#101)
 - two Circle Ring $\Phi 62.5*5$ (#102)
 - two M10*25 SHCS (#119)
4. Attach the Thigh Frame ASSY (#6) to the Front Support Frame ASSY (#4) using:
 - one Circlips For Shaft (#111)
 - one Cap ASSY (#131)
 - one M10*25 SHCS (#119)
5. Attach the FOAM Frame (#5) to the Swing Frame ASSY (#7) using:
 - one Shaft(#130)
 - two Cap ASSY (#131)
 - two M10*25 SHCS (#119)
 - two $\Phi 62*\Phi 10.5*3$ Big Washer (#300)

Note: 1. Wrench Tighten Bolts and Nylon Lock Nuts.

2. Pay attention to the relative location between the Wheel Frame ASSY (#8) and the Swing Frame ASSY (#7).

Assembly

STEP 3

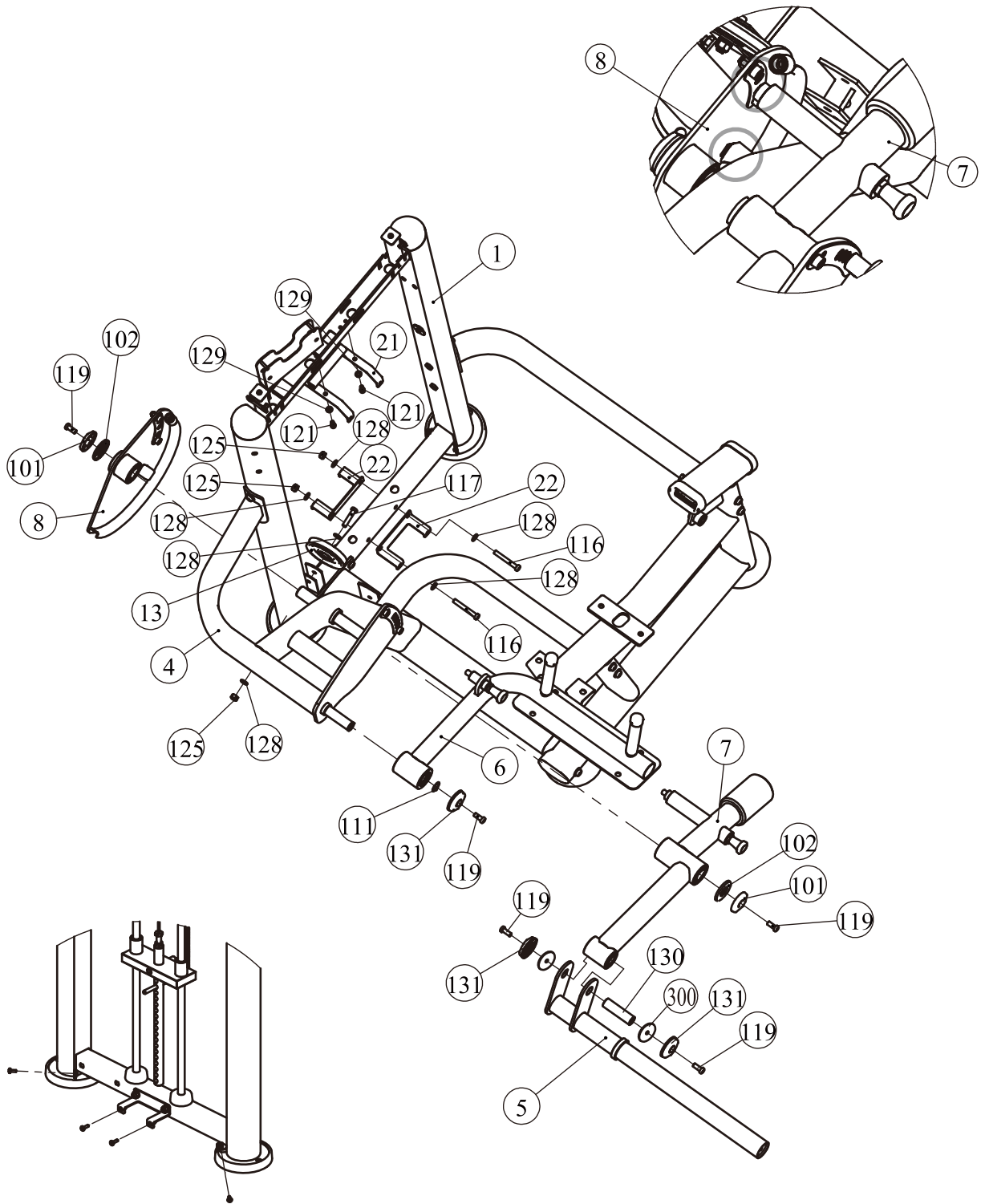

Half Rear Shroud
one Bottom Bracket ASSY

Full Shroud
two Bottom Bracket ASSY

Assembly

STEP 4

1. Attach the Plate (#11) to the Main Frame ASSY (#2) using:
 - two M10*25 FHCS (#120)
 - two M10 Nylon Lock Nut (#125)
 - two $\Phi 11*\Phi 20*2$ Flat Washer (#128)
2. Attach the Adjustable Handle Frame ASSY (#10) and Back Pad Frame ASSY (#9) to the Main Frame ASSY (#2) using:
 - one M8*20 SHCS (#121)
 - one $\Phi 9*\Phi 28*2$ Flat Washer (#126)
 - one M10*30 SHCS (#118)

Note: 1. Wrench tighten bolts and Nylon Lock Nuts.

2. Put the shaft of the Adjustable Handle Frame ASSY (#10) into Main Frame ASSY (#2) a little first. Then insert the Pin into the Main Frame ASSY (#2).

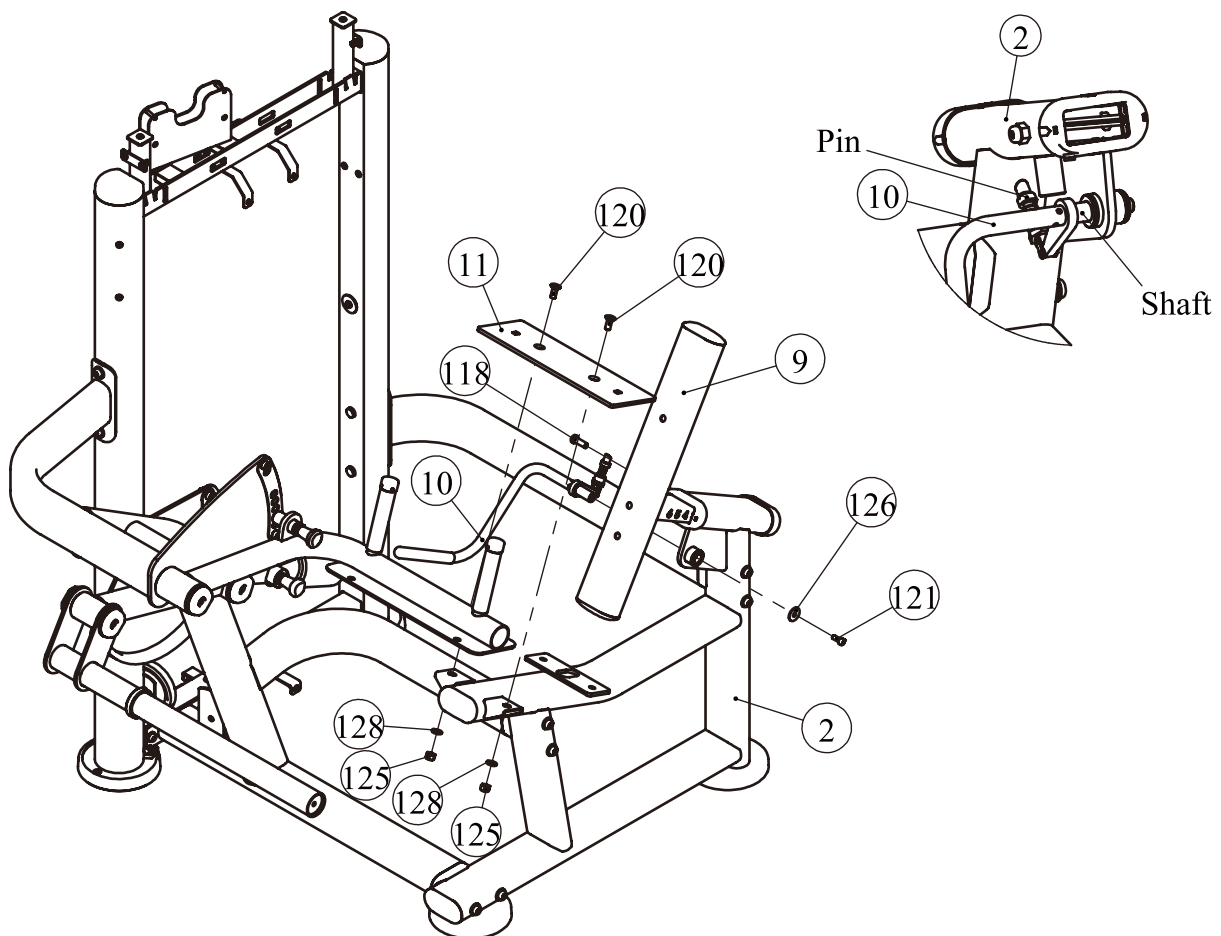

Assembly

STEP 5

Here is the assembly instruction for **160LBS Weights !**

1. Attach:

- two Guide Rod $\Phi 19 \times 1242$ (#44)
- two Weight Rubber Bumper (#103)
- fifteen Weight Plate 10LBS (#63)
- two weight stack space (#64)
- one Top Plate (#42)

to the Weight Stack Frame ASSY (#1) using:

- two Guide Rod Fixing Sleeve $\Phi 25 \times \Phi 19 \times 45$ (#106)
- two Spring (#108)

2. Attach the Selector Pin W/Coil (#104) to the Top Plate (#42).

Grade No.	Part No.	Description	QTY
63	FE97193100	10LBS Weight Plate	15
64	FEWS01ASSY	Weight Stack Space	2

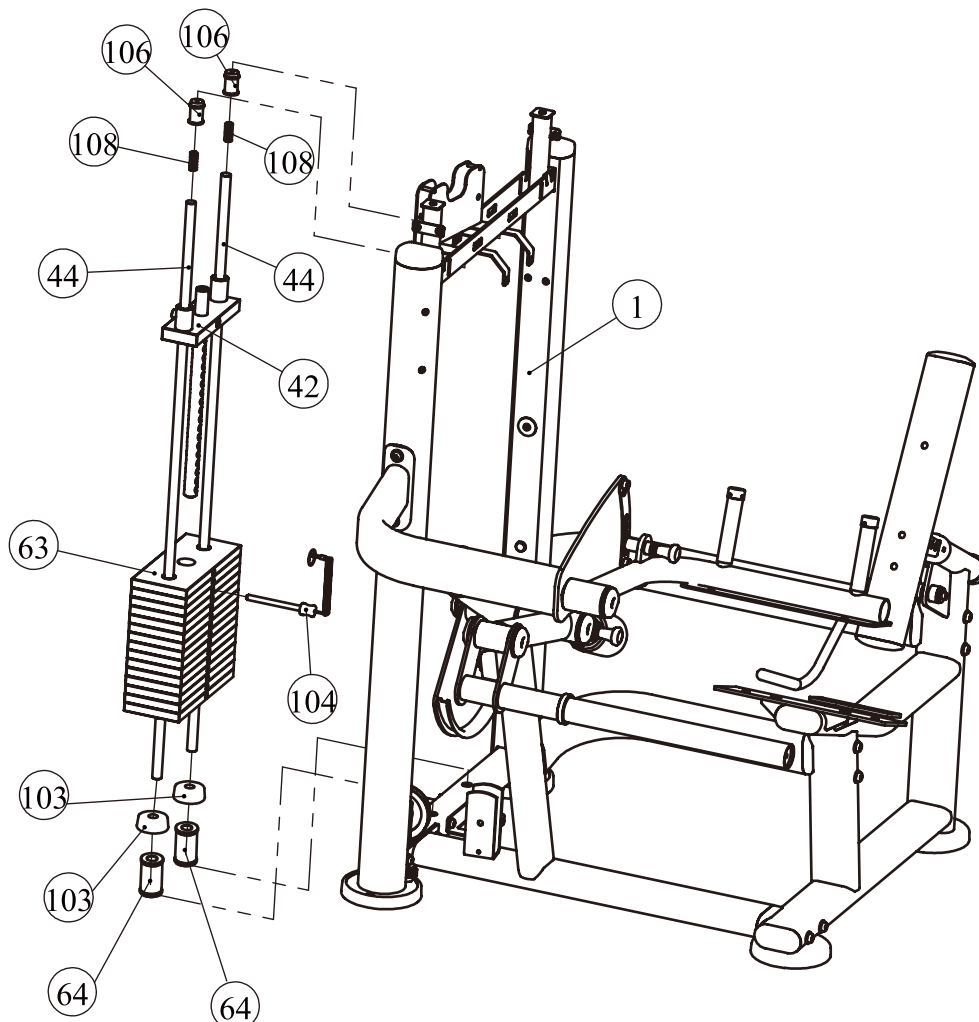

Assembly

STEP 5

Here is the assembly instruction for **200LBS Weights !**

1. Attach:

- two Guide Rod $\Phi 19 \times 1242$ (#44)
- two Weight Rubber Bumper (#103)
- nineteen Weight Plate 10LBS (#63)
- one Top Plate (#42)

to the Weight Stack Frame ASSY (#1) using:

- two Guide Rod Fixing Sleeve $\Phi 25 \times \Phi 19 \times 45$ (#106)
- two Spring (#108)

2. Attach the Selector Pin W/Coil (#104) to the Top Plate (#42).

Grade No.	Part No.	Description	QTY
63	FE97193100	10LBS Weight Plate	19

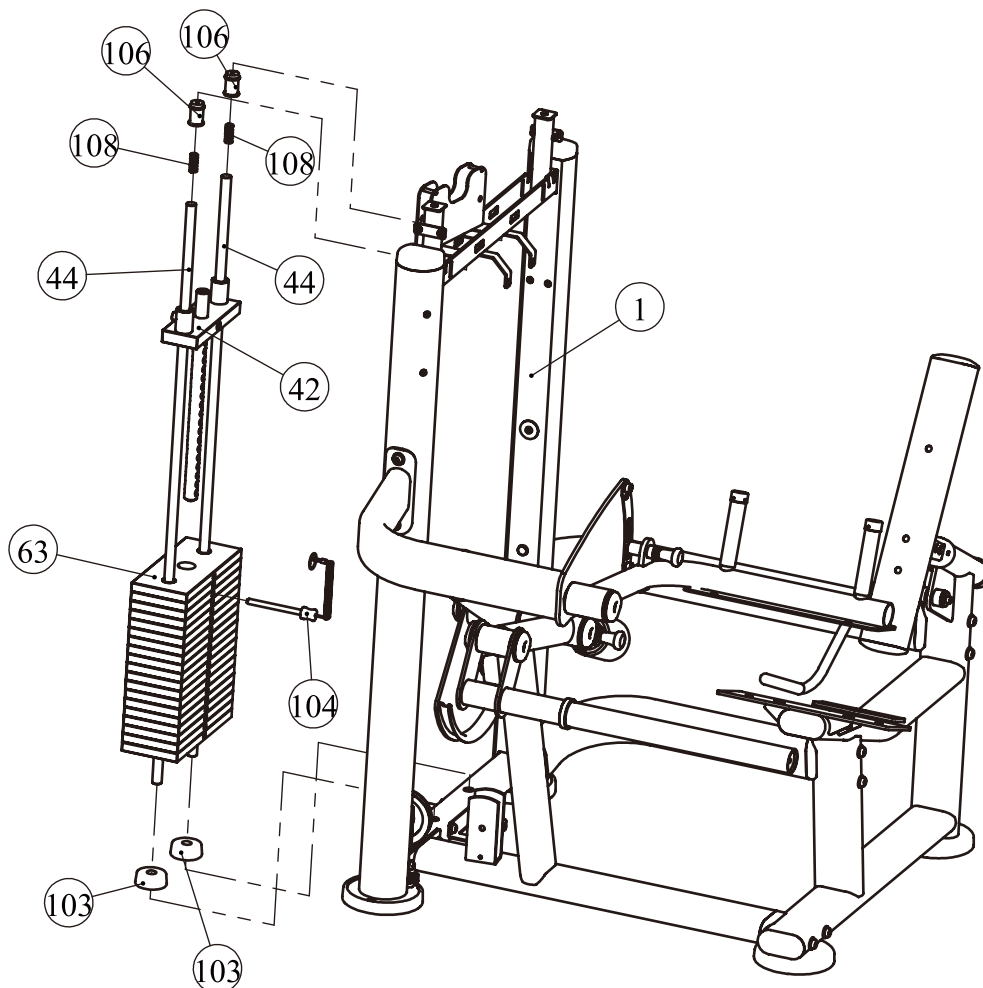

Assembly

STEP 5

Here is the assembly instruction for **235LBS Weights !**

1. Attach:

- two Guide Rod $\Phi 19 \times 1242$ (#44)
- two Weight Rubber Bumper (#103)
- fifteen Weight Plate 15LBS (#65)
- two weight stack space (#64)
- one Top Plate (#42)

to the Weight Stack Frame ASSY (#1) using:

- two Guide Rod Fixing Sleeve $\Phi 25 \times \Phi 19 \times 45$ (#106)
- two Spring (#108)

2. Attach the Selector Pin W/Coil (#104) to the Top Plate (#42).

Grade No.	Part No.	Description	QTY
65	FE97193200	15LBS Weight Plate	15
64	FEWS01ASSY	Weight Stack Space	2

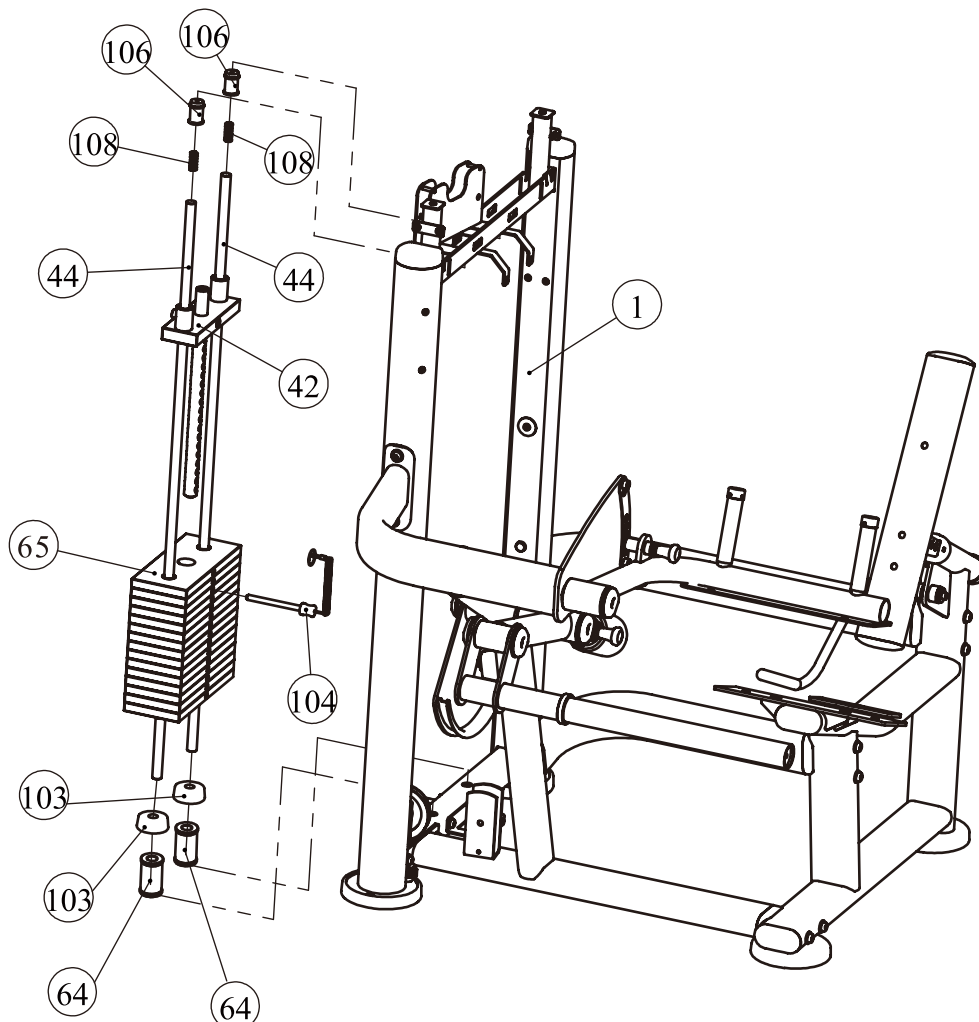

Assembly

STEP 5

Here is the assembly instruction for **295LBS Weights !**

1. Attach:

- two Guide Rod $\Phi 19 \times 1242$ (#44)
- two Weight Rubber Bumper (#103)
- nineteen Weight Plate 15LBS (#65)
- one Top Plate (#42)

to the Weight Stack Frame ASSY (#1) using:

- two Guide Rod Fixing Sleeve $\Phi 25 \times \Phi 19 \times 45$ (#106)
- two Spring (#108)

2. Attach the Selector Pin W/Coil (#104) to the Top Plate (#42).

Grade No.	Part No.	Description	QTY
65	FE97193200	15LBS Weight Plate	19

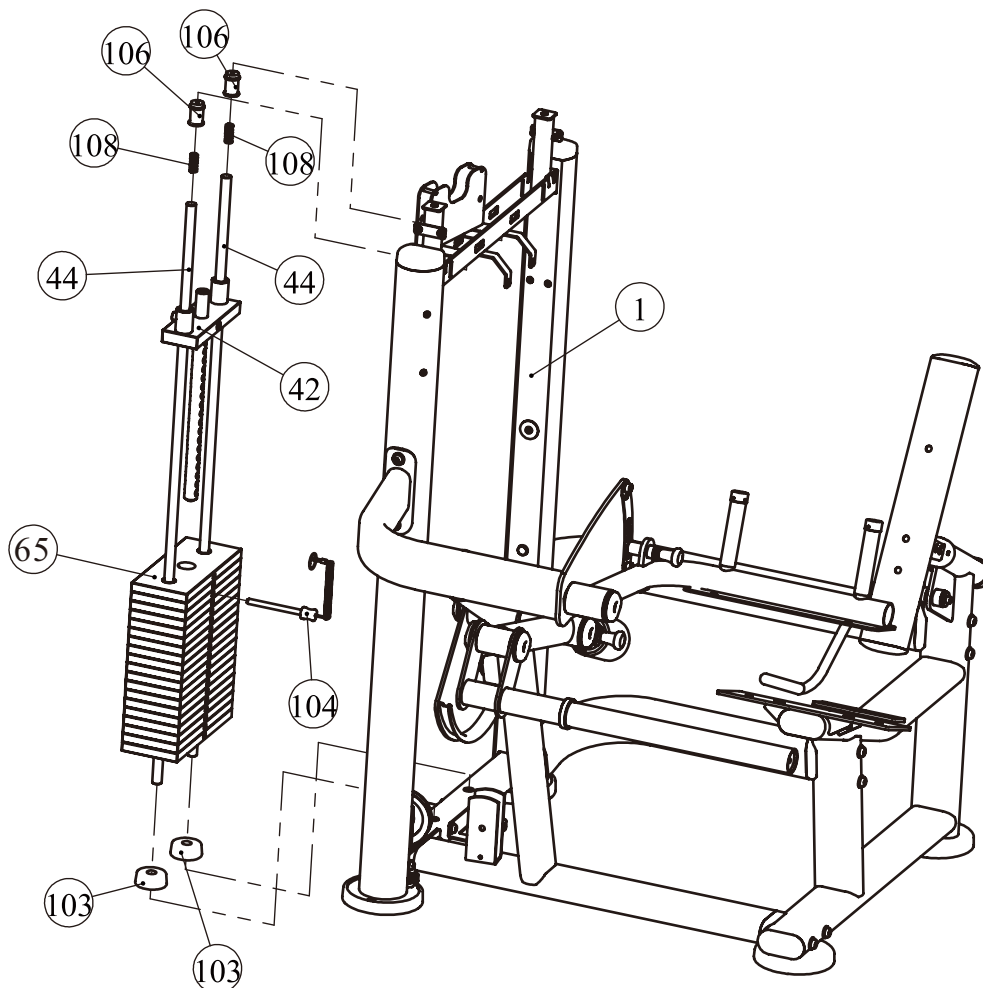

Assembly

All weight plate sticker paste schematic diagram

LBS 20	9
LBS 30	14
LBS 40	18
LBS 50	23
LBS 60	27
LBS 70	32
LBS 80	36
LBS 90	41
LBS 100	45
LBS 110	50
LBS 120	54
LBS 130	59
LBS 140	64
LBS 150	68
LBS 160	73
LBS 170	77
LBS 180	82
LBS 190	86
LBS 200	91
LBS 210	95
LBS 220	100
LBS 230	104

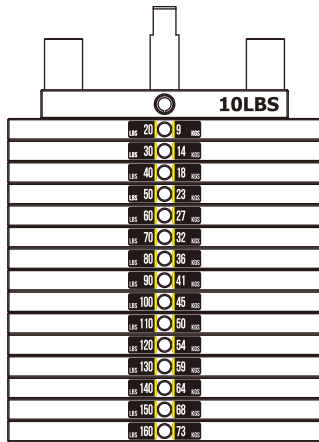

20-160LBS

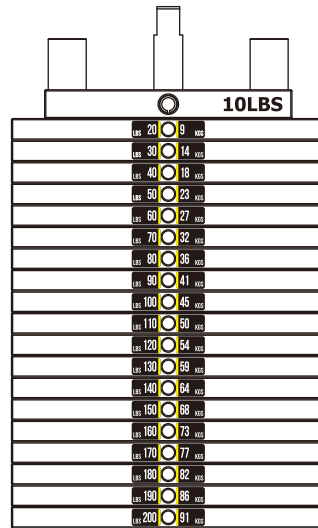

20-200LBS

LBS 25	11
LBS 40	18
LBS 55	25
LBS 70	32
LBS 85	38
LBS 100	45
LBS 115	52
LBS 130	59
LBS 145	66
LBS 160	72
LBS 175	79
LBS 190	86
LBS 205	93
LBS 220	100
LBS 235	107
LBS 250	113
LBS 265	120
LBS 280	127
LBS 295	134
LBS 310	141
LBS 325	147

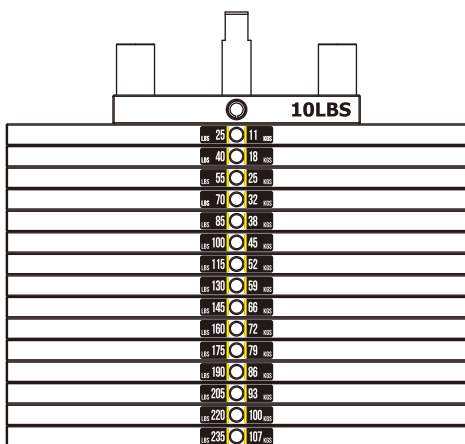

25-235LBS

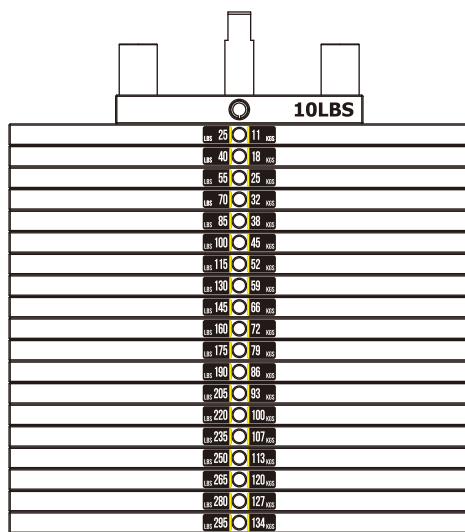

25-295LBS

Assembly

STEP 6

1. Attach two 4.5" Pulleys (#13) to the Weight Stack Frame ASSY (#1) using:
two M10*50 SHCS (#117) four $\Phi 11*\Phi 20*2$ Flat Washer (#128)
two M10 Nylon Lock Nut (#125)
2. Attach one V-type Pulley (#14) and two Pulley Cover (#17) to the Front Support Frame ASSY (#4) using:
one M10*70 SHCS (#114) one M10 Nylon Lock Nut (#125)
3. Attach the Cable ASSY (#75) to the Top Plate (#42).
4. Attach the Cable ASSY (#75) to the Wheel Frame ASSY (#8) using:
one Aluminium Sheath (#110)
5. Attach the Plug (#109) to the Wheel Frame ASSY (#8).

Note: Wrench tighten bolts and Nylon Lock Nuts.

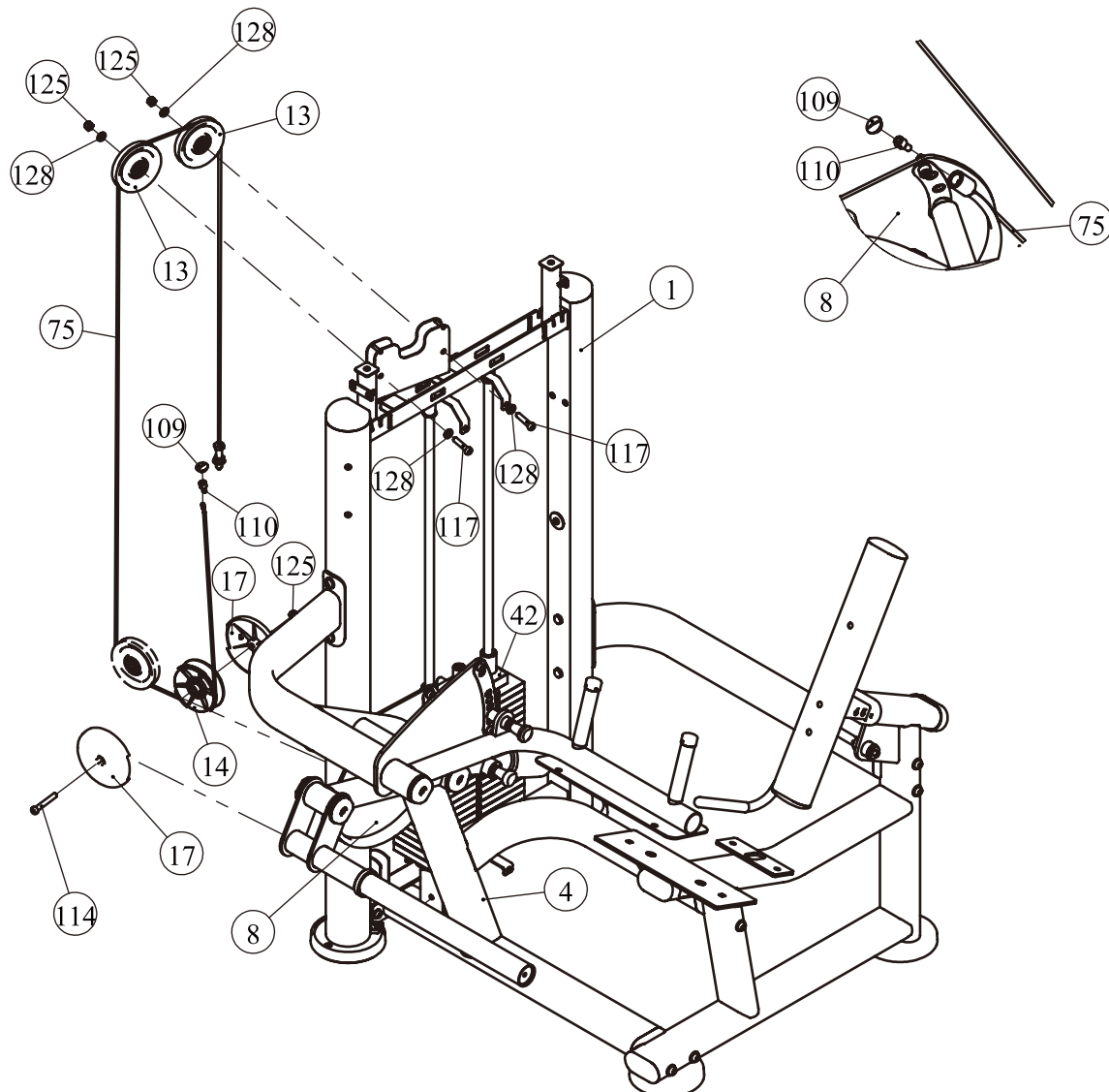

Assembly

Full Shroud

STEP 7

Tips: Pre-assemble the 8 bolt into the Weight Stack Frame ASSY and Bottom Bracket ASSY, not wrench tighten Bolts, Assemble the shroud with the bolt on. Then wrench tighten Bolts.

1. Attach the Left Front Shroud (#54) and the Front Shroud (#53) to the Weight Stack Frame ASSY (#1) and the Bottom Bracket ASSY (#22) using:
four M6*20 CRPHS (#122) two M6*16 CRPHS (#123)
2. Attach the Rear Shroud (#56) to the Weight Stack Frame ASSY (#1) and the Bottom Bracket ASSY (#22) using:
four M6*20 CRPHS (#122) two M6*16 CRPHS (#123)
3. Attach the Training Placard Cover (#52) to the Weight Stack Frame ASSY (#1) and the Top Bracket ASSY (#21) using:
two M6*20 CRPHS (#122) two M6*10 CRPHS (#124)
4. Attach the Top Rear Shroud (#55) to the Weight Stack Frame ASSY (#1) and the Top Bracket ASSY (#21) using:
four M6*20 CRPHS (#122)
5. Attach the Top Cover (#51) to the Weight Stack Frame ASSY (#1) using:
two M6*20 CRPHS (#122) two Spout Plug $\Phi 16.5 \times 6.88$ (#107)
6. Attach the Cup Holder (#92) to the Weight Stack Frame ASSY (#1) using:
two M6*20 CRPHS (#122)

Note: Wrench tighten bolts.

Half Rear Shroud

STEP 7

Tips: Pre-assemble the 4 bolt into the Weight Stack Frame ASSY and Bottom Bracket ASSY, not wrench tighten Bolts, Assemble the shroud with the bolt on. Then wrench tighten Bolts.

1. Attach the Half Rear Shroud (#200) to the Weight Stack Frame ASSY (#1) and the Bottom Bracket ASSY (#22) using:
four M6*20 CRPHS (#122) two M6*16 CRPHS (#123)
2. Attach the Training Placard Cover (#52) to the Weight Stack Frame ASSY (#1) and the Top Bracket ASSY (#21) using:
two M6*20 CRPHS (#122) two M6*10 CRPHS (#124)
3. Attach the Top Rear Shroud (#55) to the Weight Stack Frame ASSY (#1) and the Top Bracket ASSY (#21) using:
four M6*20 CRPHS (#122)
4. Attach the Top Cover (#51) to the Weight Stack Frame ASSY (#1) using:
two M6*20 CRPHS (#122) two Spout Plug $\Phi 16.5 \times 6.88$ (#107)
5. Attach the Cup Holder (#92) to the Weight Stack Frame ASSY (#1) using:
two M6*20 CRPHS (#122)

Note: Wrench tighten bolts.

Assembly

STEP 7

Full Shroud

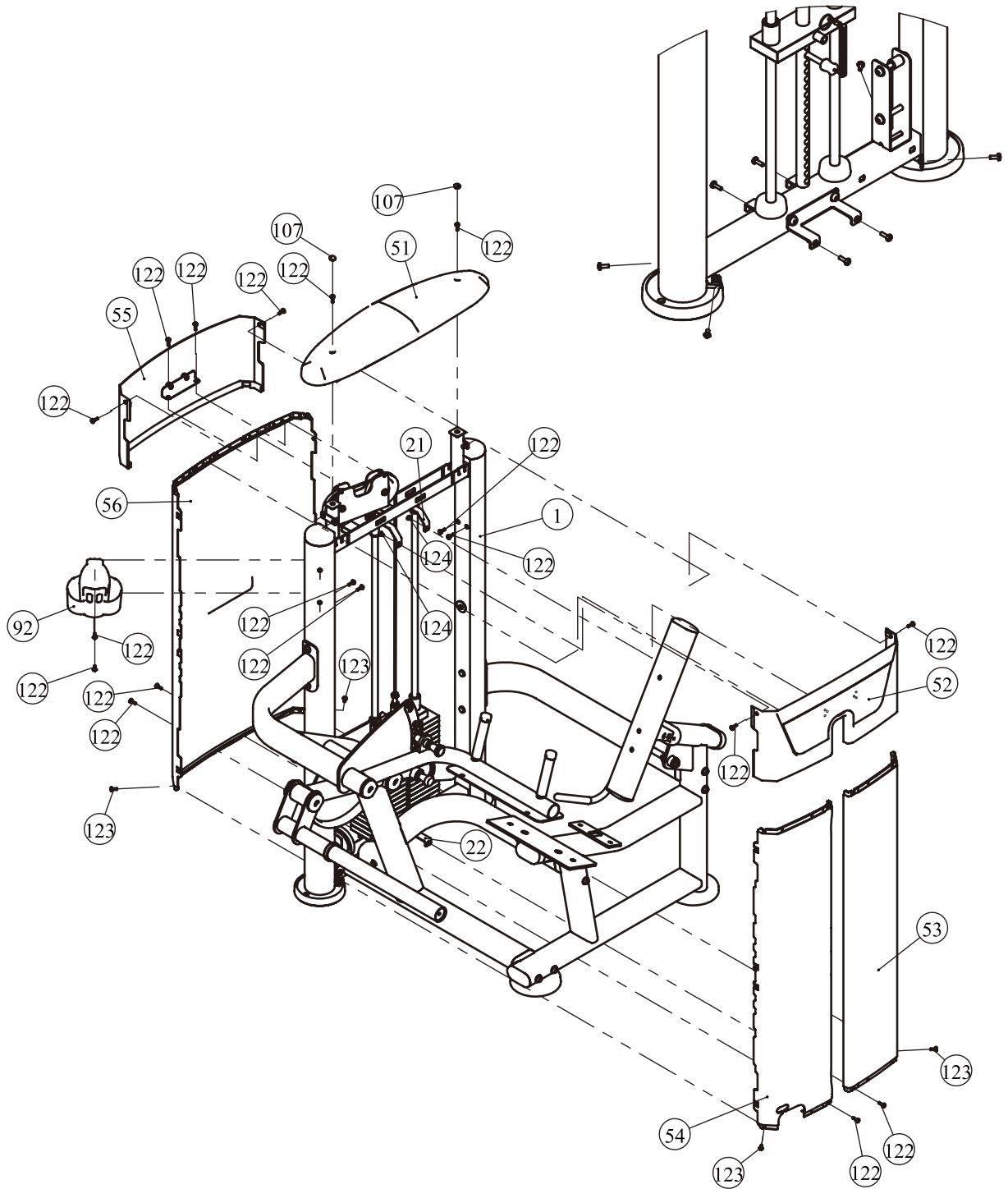

Assembly

STEP 7

Half Rear Shroud

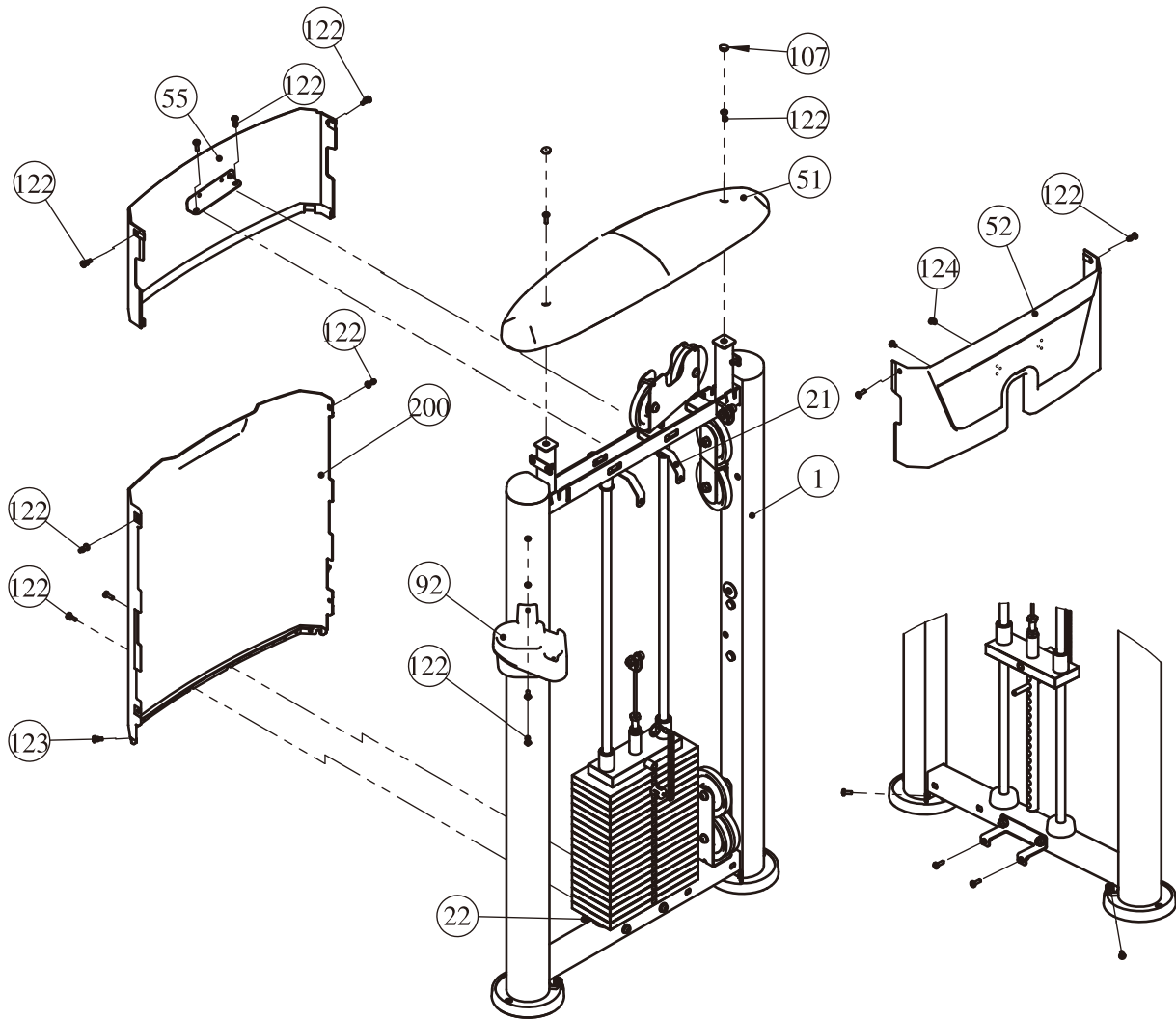

Assembly

STEP 8

1. Attach the Back Pad ASSY (#71) to the Back Pad Frame ASSY (#9) using:
two M10*80 SHCS (#115)
two $\Phi 11*\Phi 20*2$ Flat Washer (#128)
2. Attach the Seat Pad (#76) to the Main Frame ASSY (#2) and the Plate (#11) using:
four M10*30 SHCS (#118)
four $\Phi 11*\Phi 20*2$ Flat Washer (#128)
3. Attach the Thigh Pad (#78) and the Thigh Pad Shroud (#79) to the Thigh Frame ASSY (#6) using:
four M10*30 SHCS (#118)
4. Attach the FOAM ASSY (#77) to the FOAM Frame (#5) using:
one Cap $\Phi 60$ (#101)
one M10*25 SHCS (#119)

Note: Wrench tighten bolts.

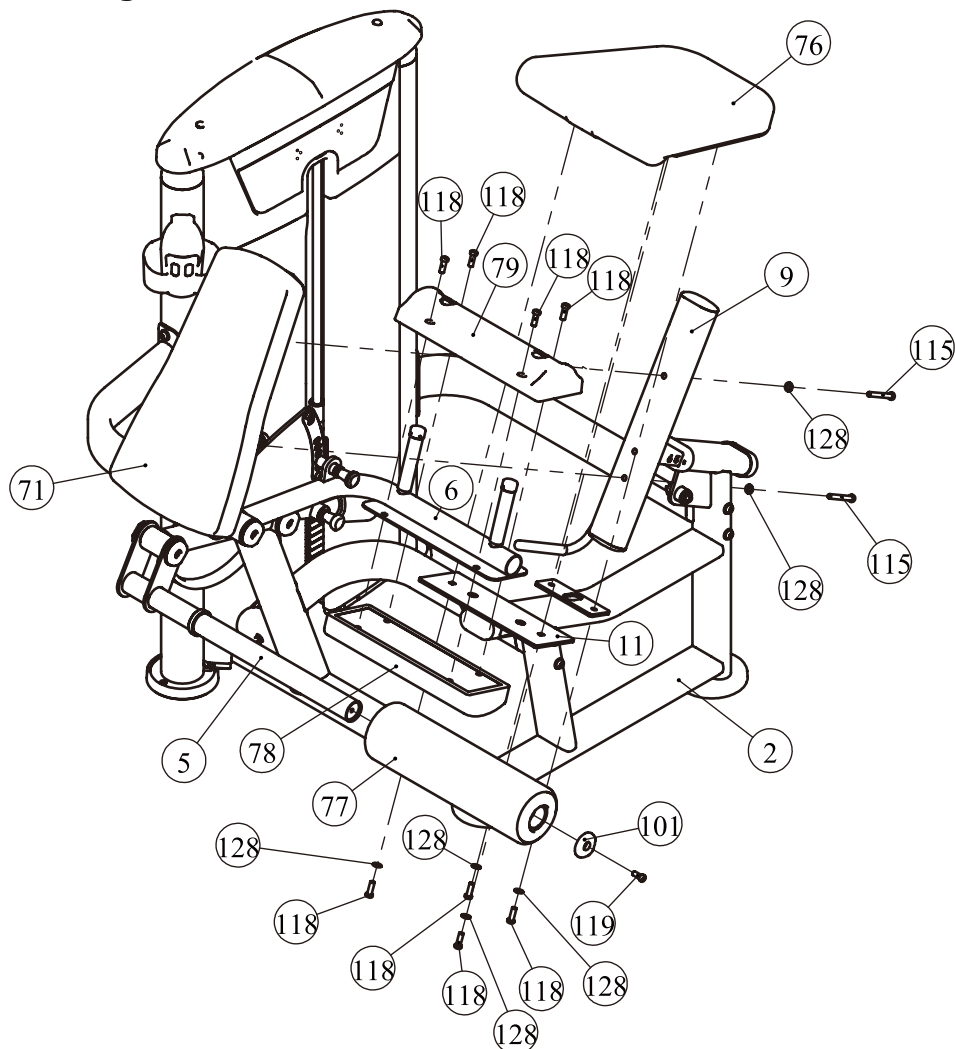

Adjust Instructions

The Back Pad adjustment

1. Pull the Adjustable Handle and adjust the Back Pad to the desired position.
2. Make sure the pin gets into the hole completely.

The Use Position adjustment

1. Pull the Adjustable Support and adjust the Thigh Pad and Foam to the desired position.
2. Make sure the pin gets into the hole completely.

The use of Selector Pin W/Coil

1. Select an appropriate weight and put the Selector Pin W/Coil into the hole on it.
2. Make sure the Selector Pin W/Coil gets into the hole completely.

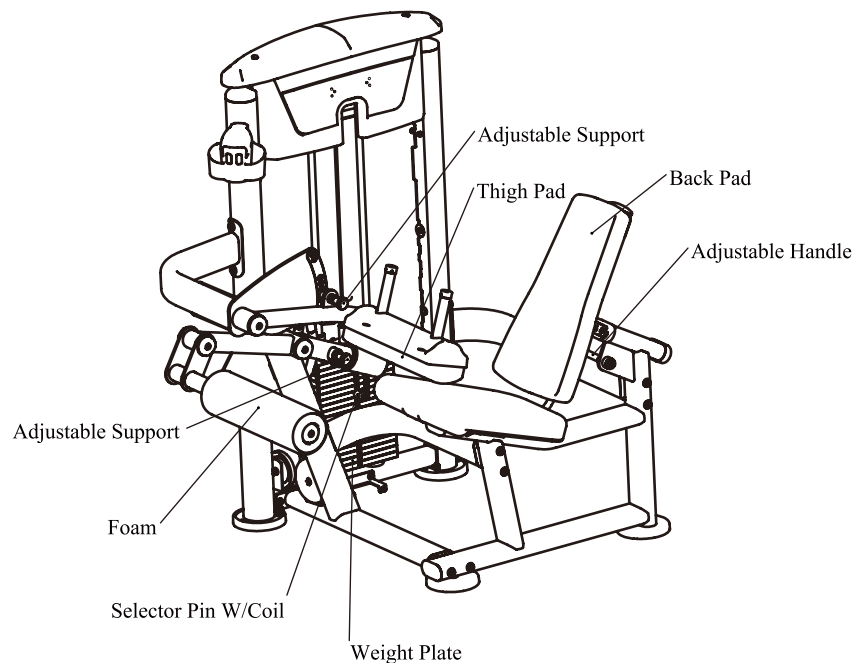

Exercise Instructions

SEATED LEG CURL

1. Select the appropriate weight.
2. Adjust back pad and thigh pad to the desired position.
3. Select desired positioning, hook both feet over the roller pad, grasp handles, pull legs down slowly.
4. Slowly return to the starting position.

Start Finish

The illustration shows a person sitting on the machine. In the 'Start' position, the person's feet are hooked over the roller pad and their legs are extended forward. In the 'Finish' position, the person has pulled their legs down towards their chest, curling their knees. To the left of the machine diagram is a silhouette of a human figure with red highlights on the hamstrings and glutes, indicating the muscles worked during the exercise.

Maintenance Schedule

ROUTINE	COMMERCIAL MAINTENANCE	HOME MAINTENANCE	LATEST DATE ENTRY					
Inspect; Links, Pull Pins, Snap Locks, Swivels, Weight Stack Pins	DAILY	WEEKLY						
Clean; Upholstery	DAILY	WEEKLY						
Inspect; Cables or Belts and their tension	DAILY	WEEKLY						
Inspect; Accessory Bars, and Handles	WEEKLY	3 MONTHS						
Inspect; All Decals	WEEKLY	3 MONTHS						
Inspect; All Nuts and Bolts, Tighten if needed	WEEKLY	3 MONTHS						
Inspect; Anti-Skid Surface	WEEKLY	3 MONTHS						
Clean & Lubricate; Guide Rods with a Teflon (PTFE) based lubricant (Superlube)	MONTHLY	3 MONTHS						
Lubricate; Seat Sleeves, Turcite Bushings, Linear Bearing	MONTHLY	3 MONTHS						
Clean and Wax; All Glossy Finishes	6 MONTHS	YEARLY						
Repack with Grease; Linear Bearings	6 MONTHS	YEARLY						
Replace; Cables, Belts and Connecting Parts	YEARLY	3 YEARS						

Your equipment comes with a commercial maintenance decal. For personal, in home use, please follow the home maintenance schedule listed above.

General Maintenance Information

Links, Pull-Pins, Snap Hooks, Swivels, Weight Stack Pins:

- * Check all pieces for signs of visible wear or damage.
- * Check springs in snap hooks and pull-pins for proper tension and alignment.
- * If the spring sticks or has lost its rigidity, replace it immediately.

Upholstery:

- * To ensure prolonged upholstery life and proper hygiene, all upholstered pads should be wiped down with a damp cloth after every workout.
- * Periodically take the time to use a mild soap or an approved vinyl upholstery cleaner to deter the onset of cracking or drying. Avoid using any abrasive cleaners or cleaners not intended for use on vinyl.
- * Replace ripped or worn upholstery immediately.
- * Keep sharp or pointed objects clear of all upholstery.

Decals:

- * Inspect and familiarize yourself with any safety warnings or other user information posted on each decal.

Nuts and Bolts:

- * Inspect all nuts and bolts for any loosening and tighten if needed.
- * Go through a re-tightening sequence periodically to ensure that all hardware is tensioned proper.

Anti-Skid Surfaces:

- * These surfaces are designed to supply secure footing and need to be replaced if they appear worn or become slippery.

Belts and Cables:

- * We use only high quality belt, and mil-spec cables.
- * Visually inspect the belts and cables for fraying, cracking, peeling or discoloration.
- * While the machine is not in use, carefully run your fingers along the belt or cable to feel for thinning or bulging areas.
- * Replace belts and cables immediately at the first signs of damage or wear. Do not use equipment until belts or cables have been replaced.

Belt and Cable Tension:

- * Referring to the Owners Manual, when belts or cables are used check all bolt attachments to be sure they are properly attached.
- * Check slack in cables and re-adjust cable tension if needed.

Seat Sleeves, Guide Rods:

- * Wipe down adjusting tubes with a dust free rag before applying lubricant.
- * Lubricate seat sleeves and Guide Rods with a Silicon or Teflon based lubricant spray.

Linear Bearings:

- * Referring to the Owners Manual carefully disassemble the bearing from its housing and place a finger full of light grease (lithium, super lube, etc.) into the inside of the bearing. Using your finger, press the grease into the ball-bearings and their tracks. Repeat until the ball-bearing tracks are full of grease. Insert the shaft back into the bearing and wipe off excess grease.

PLEASE KEEP THIS FOR YOUR RECORDS

Weight Training Tips

Use this manual to guide you through the basic exercises you can perform on your equipment. To gain maximum results and avoid possible injury, consult a fitness professional to develop your complete exercise program.

Always consult your physician before starting any exercise program.

To be successful in your exercise program, it is important to develop an understanding of the basic principles of strength training. Now that you have your equipment, it is only natural that you want to get started immediately. First, determine a set of realistic goals and objectives for yourself. By deciding on an exercise plan that is right for you prior to starting, you will contribute significantly to your success.

Warm up properly before engaging in weight resistance training. Stretching, yoga, jogging, calisthenics or other cardiovascular exercise can help prepare your body for the heavier workload of lifting weights.

Learn how to perform the exercise correctly before using heavy weight. Correct form is important to avoid injury and to ensure that you work the proper muscle groups.

Know your limitations. If you are new to weight training or are embarking on an exercise regimen after a long layoff, start slowly and build foundational strength over a longer period of time.

Pay attention to your breathing. Exhale when you exert is a general rule of thumb. Never hold your breath.

